

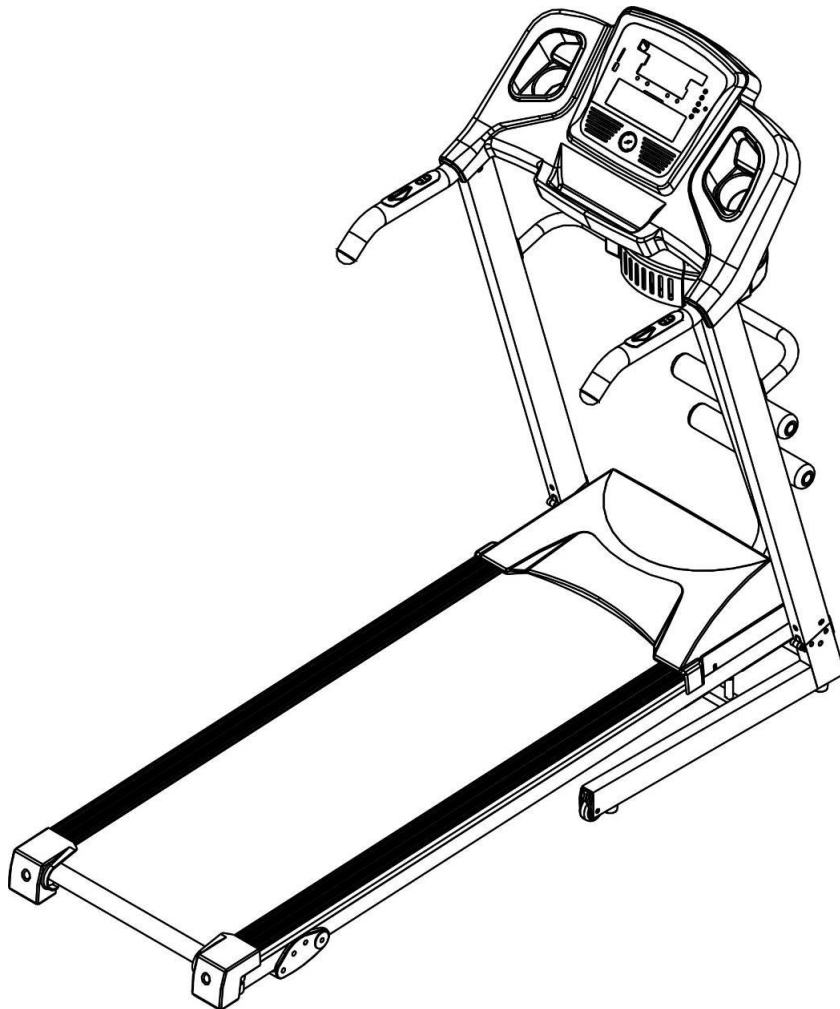

hattrick

VICORE M TREADMILL USER MANUAL



PLEASE READ ALL INSTRUCTION IN THE OWNER'S MANUAL
CAREFULLY BEFORE ASSEMBLY AND USE THE TREADMILL. AND
KEEP IT FOR FUTURE REFERENCE.

CONTENT

CONTENT	1
IMPORTANT SAFETY PRECAUTIONS	2-3
ASSEMBLY INSTRUCTIONS	4-6
FOLDING & UNFOLDING INSTRUCTIONS	7
INCLINE INSTRUCTIONS	8
GROUNDING METHODS	9
OPERATION GUIDE	10-13
GETTING STARTED GUIDE	14
SAFETY EXERCISES	15
WARM-UP EXERCISES	16
MAINTENANCE INSTRUCTIONS	17
BELT ADJUSTMENT	18
EXPLODED DRAWING	19
PARTS LIST	20-21
ERROR CODE AND SIGNIFICANCE	22

IMPORTANT SAFETY PRECAUTIONS

WARNING: Before starting any exercise program, consult with your physician or health professional, especially the person who is above 35 years old people or has some health problems before. We take no responsibility for any troubles or hurts due to above reasons. Don't power on until you finish assembly the treadmill and covering the protected top of motor.

ATTENTIONS:

1. When using this treadmill, keep attaching the safety pull pin rope to your clothes or belt.
2. Do not plug anything into any parts of this equipment, or it may damage.
3. Position the treadmill on a clear, level surface. Do not place the treadmill on thick carpet as it may interfere with proper ventilation. Also, do not place the treadmill near water or outdoors.
4. Never start the treadmill while you are standing on the walking belt. After turning the power on and adjusting the speed control, there may be a pause before the walking belt begins to move, always stand on the foot rails on the sides of the frame until the belt is moving.
5. Wear appropriate clothing when exercising on the treadmill. Do not wear long, loose fitting clothing that could become caught in the treadmill. Always wear running or aerobic shoes with rubber soles.
6. Keep small children or pet away from the treadmill during operation.
7. Do not do exercise in 40 minutes after meal.
8. The treadmill is only used for adults, child use the treadmill must have adult on side.
9. Always hold the handrails when initially walking or running on the treadmill, until you are familiar with the use of the treadmill.
10. The treadmill is for indoor equipment, do not use outdoor. Position the treadmill on a clean, level surface. Note the treadmill made by special equipment, please do not remodel or do others.
11. The power cord of motorized treadmill is specialized. If the power cord is damaged, please purchase it from distributor or contact our company directly.
12. If the treadmill should suddenly increase in speed due to an electronics failure or the speed inadvertently increased, the treadmill will come to a sudden stop when the pull pin is disengaged from the console.
13. Do not connection in the middle of power cord, extending the power cord or replace the power cord plug. Stacked weight object on the power cord or make the power cord near the high temperature heat, prohibit use the porous socket, otherwise it will cause fire or electric shock injury accident because of poor contact.

14. When the treadmill is not being used, the power cord should be unplugged and the safety pull pin removed. Note the power cord of motorized treadmill made by special equipment, and if it is broken, please contact distributor quickly.





15. The treadmill is for home use only.

17. Please do not overuse the treadmill so can avoid any injury and do not use incorrect way for your safety.

18. When the treadmill is not being used, please keep the safety pull pin in the safety place to

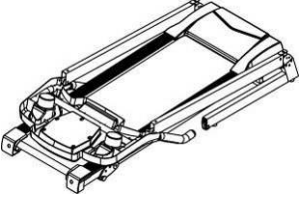
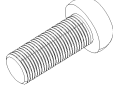
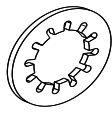
Assembly instruction

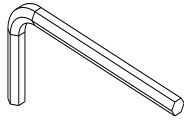
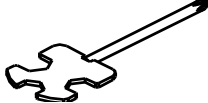
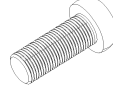
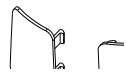
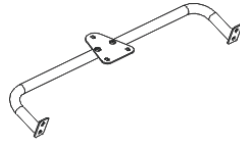
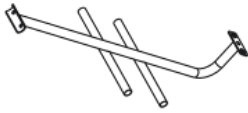
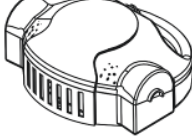
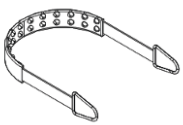
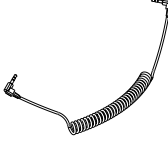
WHEN YOU OPEN THE CARTON, YOU WILL FIND THE BELOW SPARE PARTS:

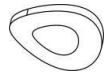
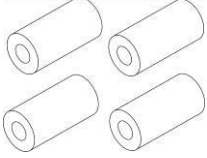
<p>A1 Main Frame 1SET</p> 	<p>D2 HALF ROUND HEAD HEX BOLT M8*15 8PCS</p> 	<p>D20 Inner Washer ϕ 8.2 ϕ 12*0.8 8PCS</p> 	<p>C14 Safety key 1PC</p> 
<p>D22 5mm Allen wrench 1PC</p> 	<p>D24 Screw driver 1PC</p> 	<p>D23 HALF ROUND HEAD HEX BOLT M8*20 4PCS</p> 	<p>D4 Bolt M8*40 2PCS</p> 
<p>A6 Massager U bracket 1PC</p> 	<p>A7 Massager support tube 1PC</p> 	<p>C20 Massager 1PC</p> 	<p>B19 Massager belt 1 PC</p> 
<p>C19 MP3 Line 1PC</p> 	<p>D19 Lock Nut M8 1PC</p> 	<p>D25 Curve washer ϕ 8.5 ϕ 16*1.5 2PCS</p> 	<p>B22 foam 4PCS</p> 

STEP 1: According to the following steps to lift up the computer bracket. Be careful not press the line when folding

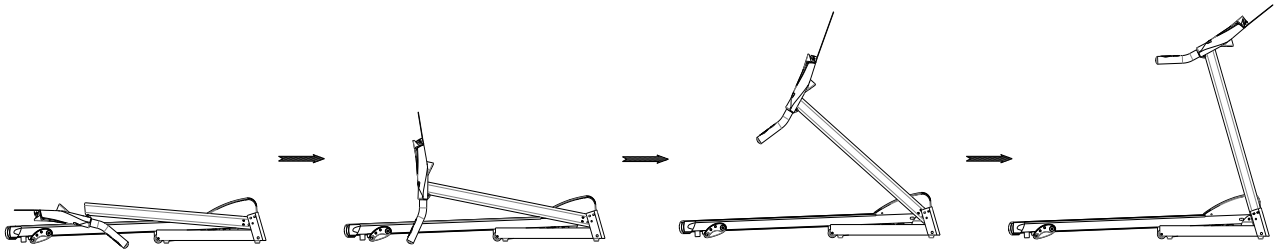

STEP 2: According to the picture to tight the bolt M8*15 (D2) and inner washer (D20)

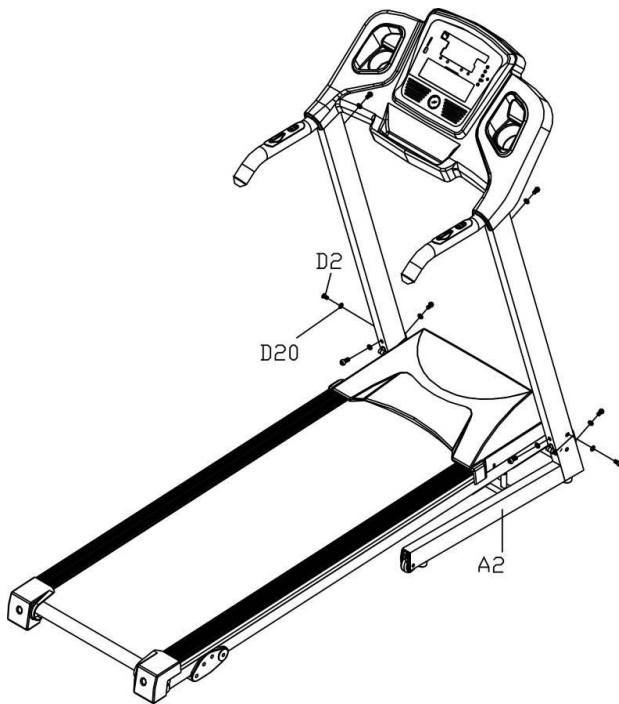

Step 3: According to the picture to assemble the massager.

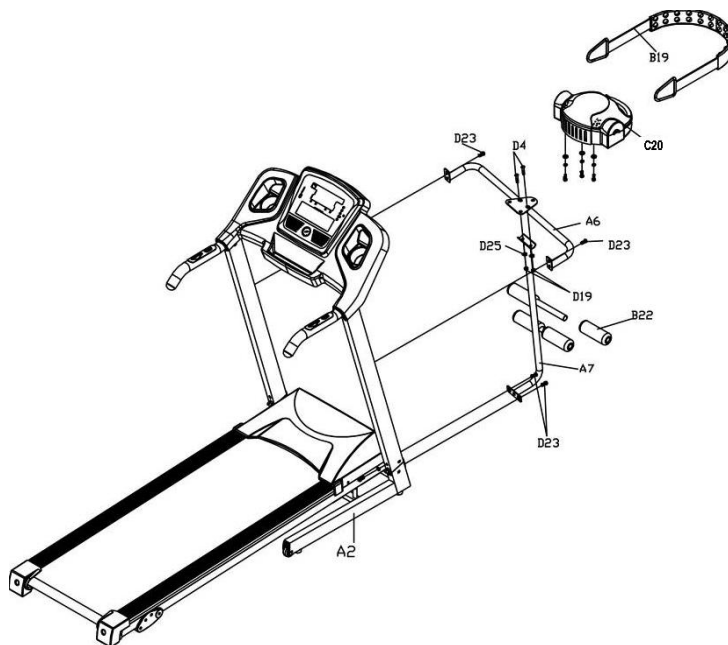

Step 4: Put on the SAFETY KEY (C14) and Mp3 line (C19)

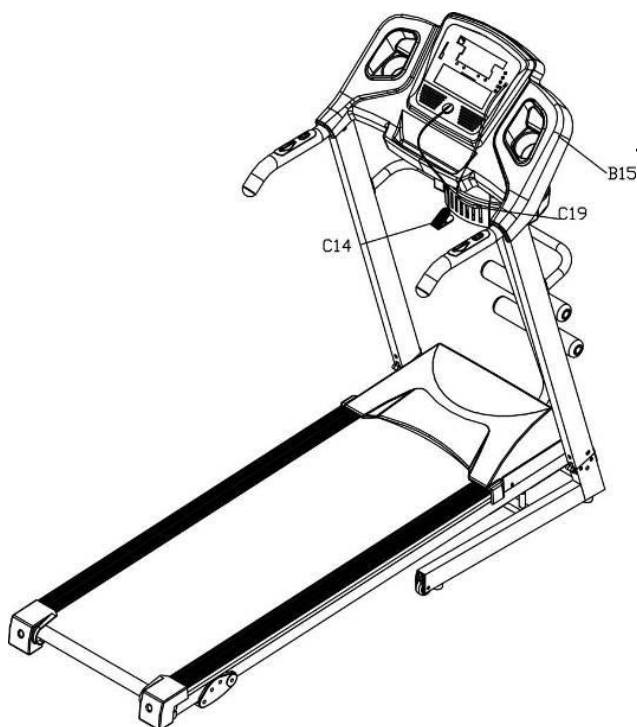

ATTENTION: Must confirm complete assembly as the required above and lock all bolts. Do the following operations after checking everything is OK. Before you use the treadmill, please read the instructions carefully.

Folding instruction

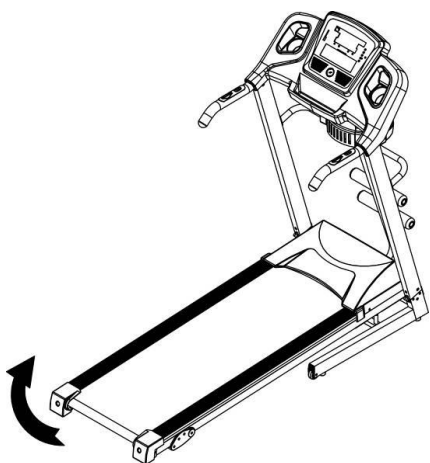

Lift up the machine and force to pull up until you heard "click" that made by safety casing stuck the pneumatic cylinder.

Unfolding instruction

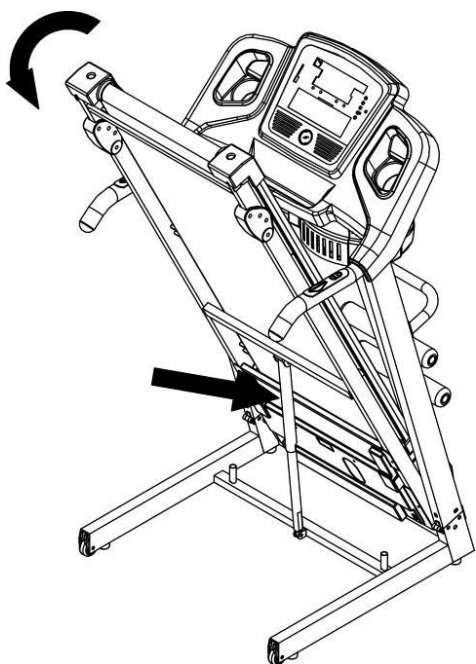

Kick the safety sleeve lightly and pull down the machine at the same time as the arrow direction. Then the machine will fall down smoothly.

Incline Instruction

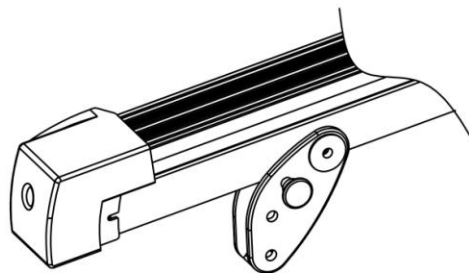
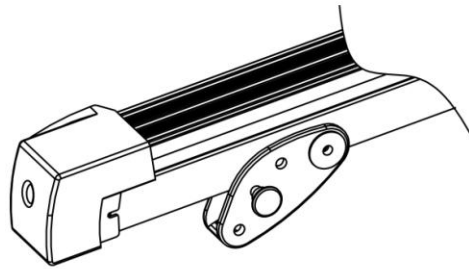
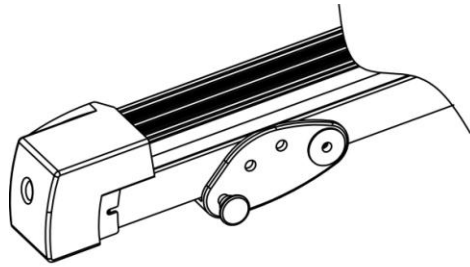

As above drawing, you can adjust lifting angle by changing pin's position. There are 3 sections adjust key to be used.

Grounding Methods

This product must be grounded. If it should malfunction or breakdown, grounding provides a path of least resistance for electric current to reduce the risk of electric shock. This product is equipped with a cord having an equipment-grounding conductor and a grounding plug. The plug must be plugged into an appropriate outlet that is properly installed and grounded in accordance with all local codes and ordinances.

DANGER – Improper connection of the equipment-grounding conductor can result in a risk of electric shock. Check with a qualified electrician or serviceman if you are in doubt as to whether the product is properly grounded. Do not modify the plug provided with the product – if it will not fit the outlet, Please find a proper outlet installed by a qualified electrician.

. This product is for use on a nominal 110-volt(or 220V) circuit and has a grounding plug . Make that the product is connected to an outlet having the same configuration as the plug. No adapter should be used with this product.

Operation Guide

1.1. WINDOW DISPLAY

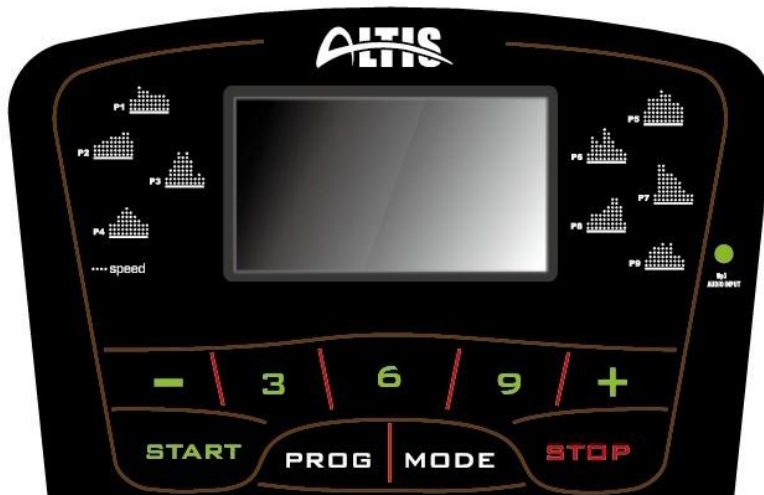

1.2. START

Normal start after 5 seconds countdown

1.3 PROGRAM

Manual mode, 12 pre-set programs, 1 body fat program, 3 countdown function

1.4. SAFETY LOCK FUNCTION

The window shows "---" when take away the safety lock and the treadmill will stop quickly with "didi" alarm noise. And put the safety lock on, the computer will display for 2 seconds and the date count down to "0"

1.5.BUTTON FUNCTION

1.5.1. START/STOP

"START"--When the treadmill is not running, press this button to start, speed is "0.8"

"STOP"--When the treadmill is running, press this button to stop, then set program default and then return to manual mode after stopped.

1.5.2 “PROGRAM” BUTTON

When the treadmill is not running, press this button can circle choose from manual mode to pre-set mode P1-P12 and body fat;

1.5.3 “MODE” BUTTON

When the treadmill is not running, press this button to choose countdown modes:“H-1”,“H-2”,“H-3”;“H-1” is the time countdown mode, and “H-2” is the distance countdown mode, “H-3” is the calorie countdown mode; press the “SPEED+/-” or “INCLINE+/-”button to adjust the data. After that, press the “START” button to start this treadmill

1.5.4 “SPEED +/- ”BUTTON

SPEED +/- --Adjust speed when treadmill start, the increment is 0.1km/time in kilometer. Press the button more than 2 seconds, and it will be up or down automatically.

1.5.5 SPEED QUICK BUTTON

Press the speed quick button 3km/h, 6km/h, 9km/h to adjust the speed directly when the treadmill is running

1.6. DISPLAY FUNCTION

1.6.1 SPEED

Display running speed

1.6.2 TIME

Display the running time or countdown time

1.6.3 DISTANCE

Display the running total distance or distance countdown.

1.6.4 CALORIE

Display the calorie or calorie countdown

1.6.5 PULSE

Display pulse data

1.6.6 ALL WINDOW DISPLAY DATA RANGE

TIME: 0:00 – 99.59(MIN)

DISTANCE: 0.00 – 99.9(KM)

CALORIES: 0.0 – 999 (C)

SPEED: 0.8-12.0(km/h)

PULSE: 50 – 200 (BPM)

1.7 PULSE FUNCTION

When the treadmill is running, hold the hand pulse about 5 seconds, it will display pulse data. The pulse data range is 50-200 times/ minute. It has heart-shaped graphics when testing pulse. This data is only for reference, can not be as medical data.

1.8 PROGRAM EXERCISE CHART-

MODE \ TIME		SET TIME / 10 = EVERY GRADE TIME									
		1	2	3	4	5	6	7	8	9	10
P1	SPEED	2	4	3	4	3	5	4	2	5	3
P2	SPEED	2	5	4	6	4	6	4	2	4	2
P3	SPEED	2	5	4	5	4	5	4	2	3	2
P4	SPEED	3	6	7	5	8	5	9	6	4	3
P5	SPEED	3	6	7	5	8	6	7	6	4	3
P6	SPEED	2	8	6	4	5	9	7	5	4	3
P7	SPEED	2	6	7	4	4	7	4	2	4	2
P8	SPEED	2	4	6	8	7	8	6	2	3	2
P9	SPEED	2	4	5	5	6	5	6	3	3	2
P10	SPEED	2	3	5	3	3	5	3	6	3	3
P11	SPEED	3	5	8	8	9	5	7	6	3	2
P12	SPEED	2	5	5	4	4	6	4	2	3	4

1.9 Manual model operation

1.9.1 Press start key, time count down 5 seconds, then treadmill will start to work with initial speed 1km/h

1.9.2 Press speed +/-, you can adjust the speed

1.9.3 Press incline+/-, you can adjust the incline

1.9.4 Press stop, you can stop treadmill at working state

1.9.5 Press quick speed key, you can quickly adjust the speed you want

1.9.6 Press quick incline key, you can quickly adjust the incline you want

1.10 COUNTDOWN FUNCTION PARAMETER DATA

Countdown time initial setting 30: 00 minutes, setting range 5: 00---99: 00 minutes , each step 1: 00.

Countdown calorie initial setting 50therm, setting range 10---990 term, each step 10.

Countdown distance initial setting 1.0km, setting range 0.5---99.9 km, each step 0.1

Cycle switch order is: manual, time, distance, calories.

1.11 BODY TESTER (FAT)

At the beginning state, press " PROGRAM" continually to enter "FAT" body fat test, window display "FAT". Press "MODE" to enter (F1 SEX, F2 AGE, F3 HEIGHT, F4 WEIGHT). Press "SPEED+", "SPEED-" to set. After setting, the computer will display F5 and grasp the hand pulse, the window will display your body quality index.

The body quality index is to test the relation between height and weight not the body scale.

The body FAT suits for any male and female to adjust the weight according together with other body quality index. The ideal FAT should be between 20-25, if under 19, it means too thin. If between 25 and 29, it means overweight, if over 30, it means obesity. (The data is just for reference and can not be as medicinal data)

01 Sex 01 Male 02 Female

02 Age 10-----99

03 Height 100----200

04 Weight 20-----150

05 FAT ≤19 Under weight

FAT = (20---25) Normal weight

FAT = (25---29) Over weight

FAT ≥30 Obesity

1.12 OTHERS

1.12.1The system will enter into power saving mode automatically if there is no any action within 10 minutes under IDLE MODE and there is no display and backlit on the computer. Press any key to

resume the system.

1.12.2 Countdown time, countdown calorie and countdown distance, you just can set one of them at one time, press last item to set running, the setting parameter is countdown, others display normal data

1.12.3 MP3 audio function: Insert the MP3 line in the input hole of the right side in the computer

Getting started guide

PREPARE

If you are around 35 years old, or have health problem, even this is your first time to do fitness exercise, please consult doctor or professional before use it.

Before do exercise, please stand on the side to learn how to operate, such as start, stop and speed adjustment. After that stand on the plastic deck of the treadmill board, catch hold of the handrail, start by 1.6--3.2 km/h low speed, stand straight, look forward, one foot try to do few times, then stand on the belt to do exercise. After adapting, you can adjust the speed to 3--5 km/h and keep doing about 10 minutes, then stop.

EXERCISE

Please stand on the side to learn how to operate, such as speed and incline, until you know it then can start do exercise. Walk 1 km by constant step need about 15-25 minutes, please record it in fact. And walk 1km by 4.8 km/h need about 12 minutes. If you can do it easily by few times, then can adjust the high speed and incline, and go on to do 30 minutes, you can take a good exercise. Before do slow walk exercise, please remember it is for your health and can not irritable.

AMOUNT OF EXERCISE

SHORTCUT—The best way to save time is do 15-20 minutes exercise.

Warm up 2 minutes by 4.8 km/h, and adjust the speed to 5.3 km/h and 5.8 km/h, continue do exercise by this two speeds. Then add 0.3 km/h per 2mins speed increase, until you feel breathing quickened but not breathe hard. Keep this speed to do exercise, if feels uncomfortable, please reduce 0.3 km/h. Leave 4 minutes to reduce speed at last. If you fell it is hard to strengthen exercises by increase speed, then you can choose the way of increase incline slowly, it also can strengthen exercise.

CONSUMPTION OF HEAT—This way can really consumption the heat.

Warm up 5 minutes by 4--4.8 km/h speed, then add 0.3 km/h per 2 minutes increasing speed, you can do 45mins on the speed that you feel it is comfortable and challenge. In order to strengthen do exercise. You can do 1 hour by this speed and add 0.3 km/h speed when you heard some business advertisements, and

return the speed back when go to next program, so at this period, the heat will be consumed enough. At last keep 4 minutes to reduce the speed.

EXERCISE FREQUENCY

Target is 3--5 times per week, do 15-60mins each time. It is better to make a time schedule, do not accord to your favor. You can get the strenuous exercise degree through adjusting speed and incline.

We'd suggest that do not set incline when start do exercise.

SAFETY EXERCISE

Please consult professional staff before do exercise. He can help recommendation exercise rate/intension and time according to your age and health condition. When running, if you feel chest tightness or chest pain, irregular Heartbeats, short of breath, dizziness or other unwell, please stop immediately! And consult professional before you want continually to do exercise. If you often use treadmill, you can choose normal walk speed or jog speed.

If you have no experience or can't make sure the best testing speed, you can reference below standard:

Speed 1-3.0 km	weak constitution people.
Speed 3.0-4.5 km	sedentary or not often exercise people.
Speed 4.5-6.0 km	walking quickly people.
Speed 6.0-7.5 km	fast walk people.
Speed 7.5-9.0 km	jogger.
Speed 9.0-12.0 km	intermediate speed runner.
More than 12.0 km	excellent runner.

ATTENTION: It is suitable for walker to choose less than or equal to 6 km speed.

Warm-up Exercise

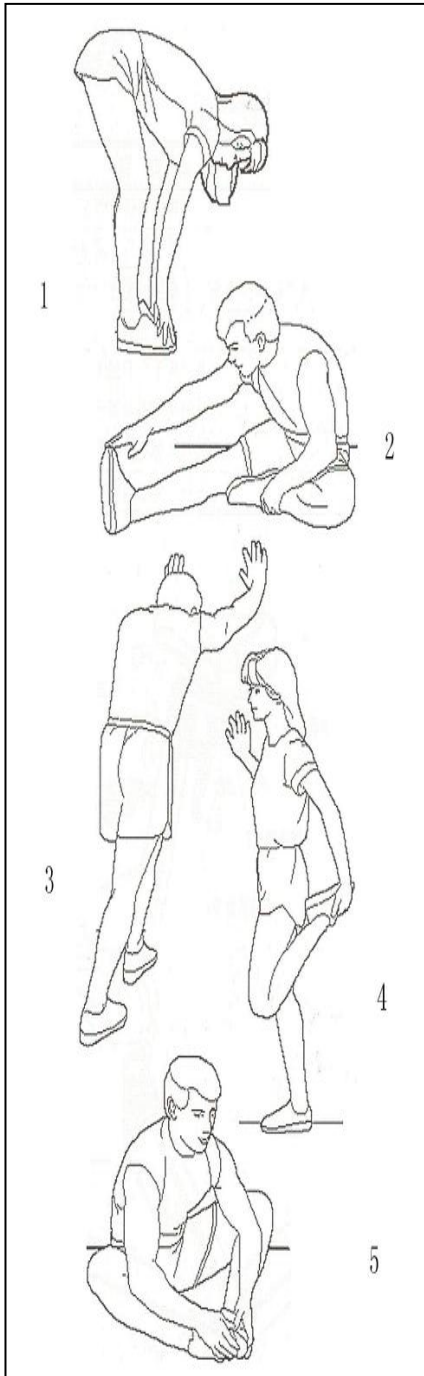

It is better to do some warm-up exercise. Warm the muscle easy stretch, so use 5-10 mins to warm-up. Then stop and according below method to do stretch exercise for five times, and each foot do 10 seconds or more every time. After running, do those stretch exercises again

1. Reach Down : Knees slightly bent and body slowly bent forward, back and shoulders relax, trying to touch toes. Keep 10-15 seconds and relax. Repeat 3 times(See picture 1).

2. Hamstrings Stretches: Sitting on a clean cushion, put one leg straight, the other inward and close to the inside of the straight leg. Try to touch your toes with your hands. Keeping for 10 to 15 seconds, and relax. Repeat 3 times for each leg (See picture 2).

3. Crus and Foot Tendon Stretches: Standing with two hands on the wall or tree, one leg behind. Keeping your legs straight and the heel on the ground, tilt to the wall or tree. Keep 10 to 15 seconds, and relax. Repeat 3 times for each leg (See picture 3).

4. Quadriceps Stretches: Keeping your balance with your left hand holding on the wall or table, then stretch your right heel toward your buttocks slowly, until you feel very tense in the front of your thigh. Keep 10 to 15 seconds, and relax. Repeat 3 times for each leg (See picture 4).

5. Sartorius (Inner Muscles of the Thigh Muscle Stretches: Sitting down with your soles opposite and knees outward Pull your feet toward your groin Keep 10 to 15 seconds, and relax. Repeat 3 times (See picture 5).

Maintenance Instruction

WARNING: Please make sure pull out the treadmill's power plug before cleaning or maintaining the product.

CLEANSING: General cleaning of the unit will greatly prolong the treadmill's life.

Keep treadmill clean by dusting regularly. Be sure to clean the exposed part of the deck on either side of the walking belt and also the side rails. This reduces the build up of foreign material underneath the walking belt. Make sure the shoes are clean. The top of the belt may be cleaned with a wet soapy cloth. Be careful to keep liquid away from inside the motorized treadmill frame or from underneath the belt.

WARNING: Always unplug the treadmill from the electrical outlet before removing the motor cover. At least once a year remove the motor cover and vacuum under the motor cover.

This treadmill's walking belt and deck are equipped with a pre-lubricated, low maintenance deck system. The belt/ deck friction may play a major role in the function and life of your treadmill, thus requiring periodic lubrication. We recommend a periodic inspection of the deck.

We recommend lubrication of the deck according to the following timetable:

Light user (less than 3 hours/ week)	Every 60 days
Medium user (3-5 hours/ week)	Every 45 days
Heavy user (more than 5 hours/ week)	Every 30 days

We suggest you buy lubricating oil from local distributors or contact our company directly.

Pay attention, any other maintains please ask professionals for help.

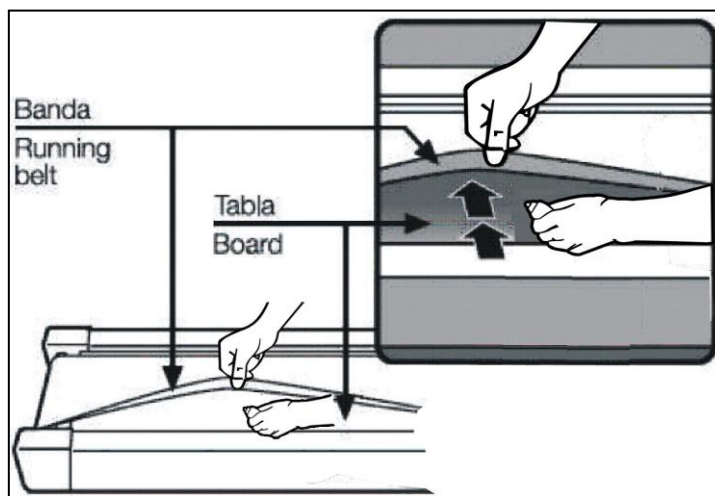

Place treadmill on a level surface. Make treadmill run at approximately 6-8 km/h, observe the running belt deviate condition.

Belt Adjustment

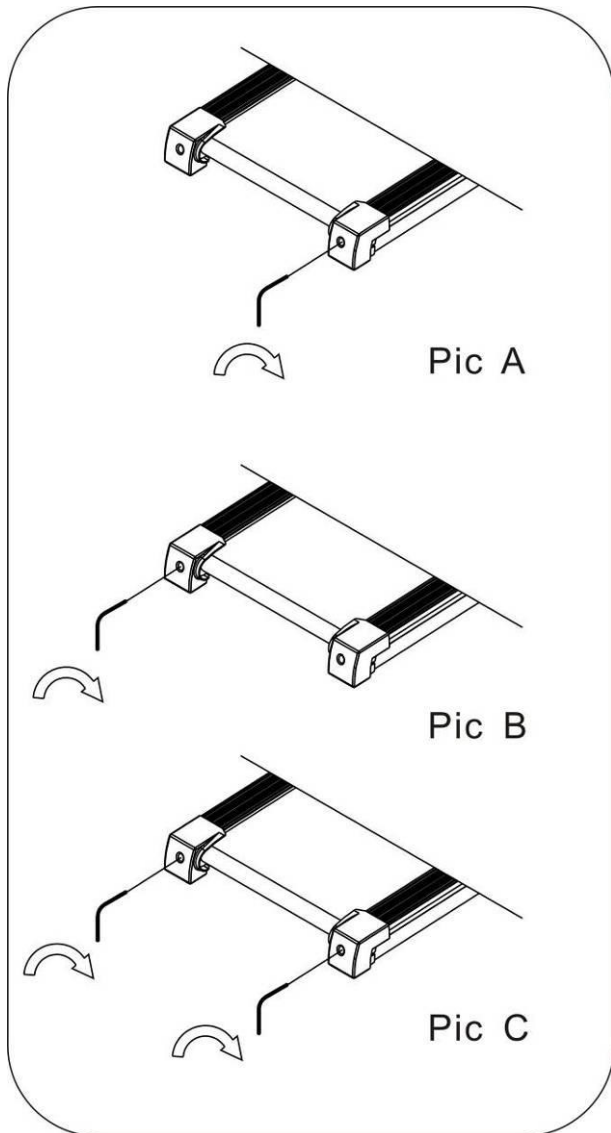

If the belt has drifted to the right, unplug the safety lock and power switch, and turn the right adjusting bolt $1/4$ turn clockwise, then insert the power switch and safety lock, make the treadmill running, observe the running belt deviate condition. Repeat above steps until the running belt be placed in the middle. **See picture A**

Once the treadmill belt swerving to the left, unplug the safety lock, turn off the power, then with the left adjusting bolt clockwise rotation $1/4$ laps, and turn on the safety lock and power to make treadmill running, checking the deviation of the treadmill belt. Repeat the above steps until the belt centered. **See picture B**

The treadmill belt will gradually relax after above steps or after a period of time using, unplug the safety lock, and turn off the power, with the two adjusting bolt clockwise rotation $1/4$ laps, and turn on the safety lock and power to make treadmill running, then standing on the belt to confirm the tightness. Repeat the above steps until the belt moderate tightness.

See picture C

Exploded Drawing

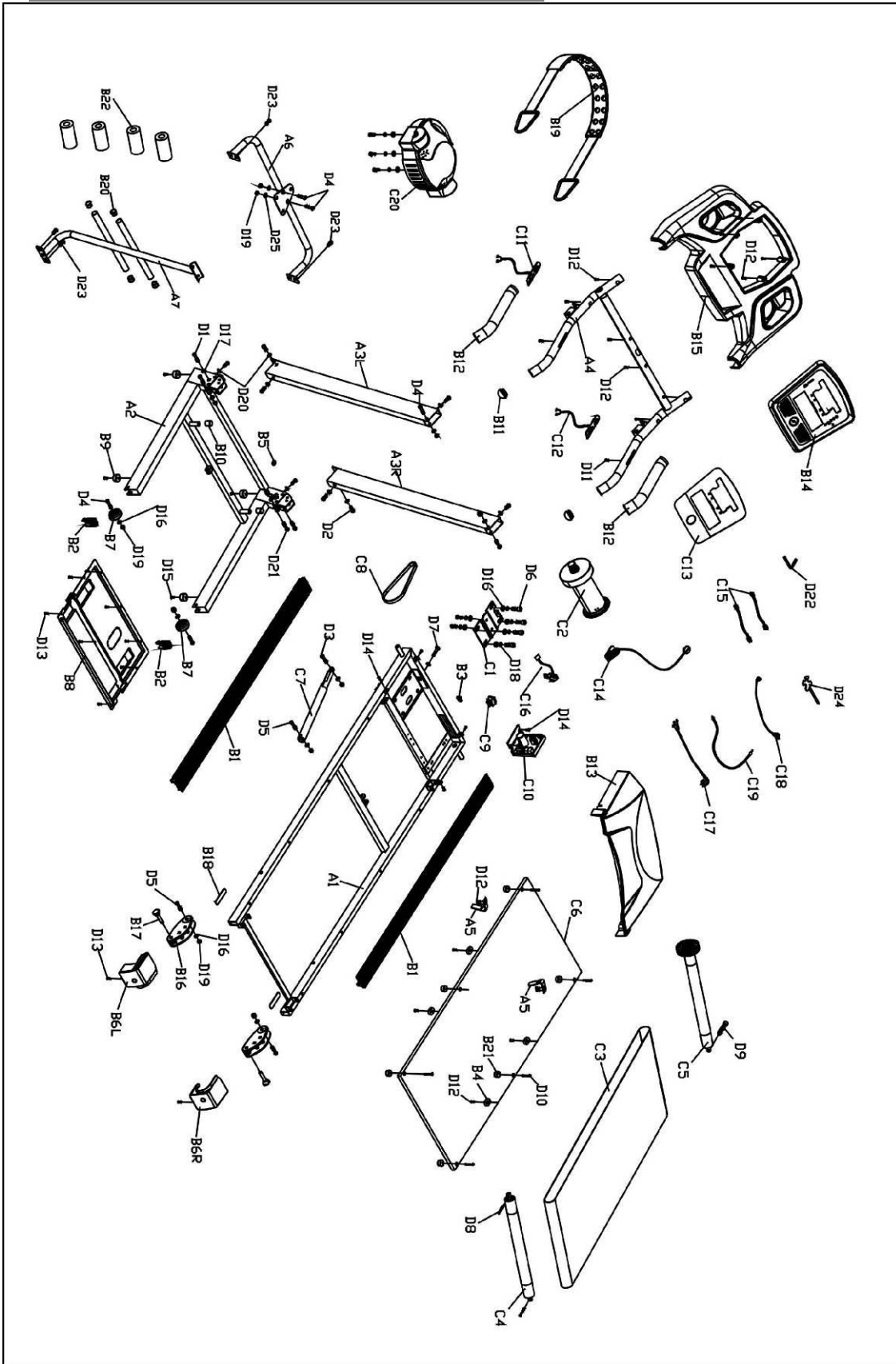

Parts list

NO.	DESCRIPTION	REMARK	QTY	NO.	DESCRIPTION	REMARK	QTY
A1	MAIN FRAME		1	B19	MASSAGER BELT		1
A2	BASE FRAME		1	B20	INNER PIPE PLUG		4
A3L	LEFT UPRIGHT		1	B21	CUSHION		6
A3R	RIGHT UPRIGHT		1	B22	SIT UP FOAM		4
A4	COMPUTER BRACKET		1	C1	MOTOR BRACKET		1
A5	BELT GUIDE		2	C2	DC MOTOR		1
A6	MASSAGER U BRACKET		1	C3	RUNNING BELT		1
A7	MASSAGER SUPPORT TUBE		1	C4	REAR ROLLER		1
B1	SIDE RAILS		2	C5	FRONT ROLLER		1
B2	MOVING WHEELS PLUG		2	C6	RUNNING BOARD		1
B3	POWER BUCKLE		1	C7	CYLINDER		1
B4	SQUARE CUSHION		4	C8	BELT		1
B5	WIRE PLUG		1	C9	POWER SWITCH		1
B6L	LEFT END CAP		1	C10	CONTROLLER		1
B6R	RIGHT END CAP		1	C11	SWITCH HANDLE PULSE		1
B7	MOVING WHEELS		2	C12	SPEED HANDLE PULSE		1
B8	MOTOR BOTTEM COVER		1	C13	OVERLAY		1
B9	FLAT PAD		4	C14	SAFETY KEY		1
B10	CUSHION		2	C15	SINGLE LINE		2
B11	INNER PIPE PLUG		2	C16	SPEED SENSOR		1
B12	HANDRAIL FORM		2	C17	POWER WIRE		1
B13	MOTOR COVER		1	C18	COMPUTER BOTTOM WIRE		1
B14	COMPUTER PANEL		1	C19	MP3 LINE		1
B15	CUMPUTER TOP COVER		1	C20	MASSAGER		1
B16	3 SECTION MANUAL INCLINE		2	D1	HALF ROUND HEAD HEX BOLT	M10*45	2
B17	PIN		2	D2	HALF ROUND HEAD HEX BOLT	M8*15	8
B18	RUBBER COVER		2	D3	HALF ROUND HEAD HEX BOLT	M8*30	1

NO .	DESCRIPTION	REMARK	QTY	NO .	DESCRIPTION	REMARK	QTY
D4	HALF ROUND HEAD HEX BOLT	M8*40	6	D15	CROSS HEAD SCREQ	M5*20	4
D5	HALF ROUND HEAD HEX BOLT	M8*45	3	D16	FLAT WASHER	φ 8.5* φ 16*t1.5	13
D6	ROUND HEAD HEX BOLT	M8*20	4	D17	FLAT WASHER	φ 10.5* φ 20*t1. 5	2
D7	HALF ROUND HEAD HEX BOLT	M8*45	1	D18	SPRING WASHER	M8	4
D8	ROUND HEAD HEX BOLT	M6*60	2	D19	LOCK NUT	M8	10
D9	ROUND HEAD HEX BOLT	M6*45	1	D20	INNER WASHER	φ 8.2 φ 12*0.8	8
D10	Hex screw	M6*30	6	D21	FLAT WASHER	M8*35	2
D11	Cross self-tapping screw	ST4.2*25	2	D22	ALLEN WRENCH	S5	1
D12	Cross self-tapping screw	ST4.2*15	15	D23	FLAT WASHER	M8*20	4
D13	Cross self-tapping screw	ST4.2*15	14	D24	SCREW DRIVER	14. 15. 17	1
D14	Cross self-tapping screw	M5*15	7	D25	CURVE WASHER	φ 8.5* φ 16*t1.5	2

Error code and significance

Fault Code	Fault Description	Fault Processing
E1	Communication abnormal: The control and computer has abnormal communication after start	The controller is not working and going into fault. The machine can not run, the computer shows fault code "E1", and the buzze will ring three times. Possible Reasons: Communication obstructed between controller and computer, please check the wire and make sure the wire connect well and the wire without any damager..
E2	No Speed Wireless Sensor Network: Can't receive the motor speed sensor feedback above three seconds.	Stop and go into fault status, computer buzze will ring 3 tones and shows fault code"E2". Other areas show blank. After 10 seconds will go into ready mode, and can restart. Possible Reasons: Can't receive the motor speed sensor feedback above three seconds, please check sensor plug and motor connect wire and the controller.
E3	The motor wire is not connecting well	Stop and go into fault status, computer buzze will ring 3 tones and shows fault code"E3". Other areas show blank. After 10 seconds will go into ready mode, and can restart. Possible Reasons: Check if the motor wire is connected well and re-connect the motor wire well if not; check if the controller has the smell and change the controller if have
	Current overload Protection , the motor electrical is overload	Stop and go into fault status, computer buzze will ring 3 tones and shows fault code"E3". Other areas show blank. After 10 seconds will go into ready mode, and can restart. Possible Reasons: Over the rated load cause too much electricity that make system Self-preservation or some parts blocked and make DC motor can't process. Adjust the machine and restart. Another please check the DC motor or controller have any burned smell or not. If yes, please change the motor or controller. Another make sure the power and voltage is comply with standard.
E6	Explosion-Proof Protection: Some unusual condition of power or voltage that cause damage to the motor drive circuit.	Stop and go into fault status, computer buzze will ring 3 tones and shows fault code"E6". Other areas show blank. If recover then go into ready mode, then can restart. Possible Reasons: The power voltage is less than normal or the controller has some problems. Make sure the motor wire is connecting well.