



hattrick

HATTRICK RB-4000 MOTORIZED TREADMILL

OPERATING INSTRUCTIONS MANUAL



IMPORTANT SAFETY INSTRUCTIONS

WARNING - Read all instructions before using this treadmill. It is important your treadmill receives regular maintenance to prolong its useful life. Failing to regularly maintain your treadmill may void your warranty.

Danger—To reduce the risk of electric shock disconnect your treadmill from the electrical outlet prior to cleaning and/or service work.

DO NOT USE AN EXTENSION CORD: DO NOT ATTEMPT TO DISABLE THE GROUNDED PLUG BY USING IMPORPER ADAPTERS OR IN ANY WAY MODIFY THE CORD SET.

- 1) Install the treadmill on a flat level surface with access to correct voltage and frequency, grounded outlet.
- 2) Do not operate treadmill on deeply padded, plush or shag carpet. Damage to both carpet and treadmill may result.
- 3) Do not block the rear of the treadmill. Provide a minimum of 1 metre clearance between the rear of the treadmill and any fixed object.
- 4) Place your unit on a solid, level surface when in use.
- 5) Never allow children on or near the treadmill.
- 6) When running, make sure the plastic clip is fastened on your clothing. It is for your safety, should you fall or move too far back on the treadmill.
- 7) Keep hands away from all moving parts.
- 8) Never operate the treadmill if it has a damaged cord or plug.
- 9) Keep the cord away from heated surfaces.
- 10) Do not operate where aerosol spray products are being used or where oxygen is being administered. Sparks from the motor may ignite a highly flammable environment.
- 11) Never drop or insert any object into any openings.
- 12) The treadmill is intended for in-home use only and not suitable for long time running.
- 13) To disconnect, turn all controls to the off position, remove the safety key, and then remove the plug from the outlet.
- 14) The pulse sensors are not medical devices. Various factors, including the user's movement, may affect the accuracy of heart rate readings. The pulse sensors are intended only as exercise aids in determining heart rate trends in general.
- 15) Use handrails provided; they are for your safety.
- 16) Wear proper shoes. High heels, dress shoes, sandals or bare feet are not suitable for use on your treadmill. Quality athletic shoes are recommended to avoid leg fatigue.
- 17) Allowed temperature: 5 to 40 degrees.

Remove the safety key after use to prevent unauthorized treadmill operation.

WARNING:

Once finding any breakdown or damage occurred, stop the treadmill and consult with local agent to find out the solution. In order to secure the personal safety, don't make any maintenance without a qualified engineer.

IMPORTANT ELECTRICAL INFORMATION

WARNING!

- 1) NEVER use a ground fault circuit interrupt (GFCI) wall outlet with this treadmill. Route the power cord away from any moving part of the treadmill including the elevation mechanism and transport wheels.
- 2) NEVER operate treadmill on Generator or UPS power supply.
- 3) NEVER remove any cover without first disconnecting AC power.
- 4) NEVER expose this treadmill to rain or moisture. This treadmill is not designed for use outdoors, near a pool, or in any other high humidity environment.

IMPORTANT OPERATION INSTRUCTIONS

- 1) Insert the power plug into the socket directly.
- 2) The constant running time is less than 2 hours. Be sure to read the entire manual before operating your machine.
- 3) Understand that changes in speed and incline do not occur immediately. Set your desired speed on the computer console and release the adjustment key. The computer will obey the command gradually.
- 4) Use caution while participating in other activities while walking on your treadmill; such as watching television, reading, etc. These distractions may cause you to lose balance or stray from walking in the centre of the belt; which may result in serious injury.
- 5) In order to prevent losing balance and suffering unexpected injury, **NEVER** mount or dismount the treadmill while the belt is moving. This unit starts with a very low speed. Simply standing on the belt during slow acceleration is proper after you have learned to operate this machine.
- 6) Always hold on to handrail while making control changes.
- 7) A safety key is provided with this machine. Remove the safety key will stop the walking belt immediately; the treadmill will shut off automatically. Insert the safety key will reset the display.
- 8) Do not use excessive pressure on console control keys. They are precision set to function properly with little finger pressure.
- 9) This appliance is not intended for use by persons (including children) with reduced physical, sensory or mental capabilities, or lack of experience and knowledge, unless they have been given supervision or instruction concerning use of the appliance by a person responsible for their safety, Children should be supervised to ensure that they do not play with the appliance.
- 10) Please consult your doctor at first before running, if you have one of the following diseases:
 - a. Cardiopathy, hypertension, sugar diabetes, respiratory disease, smoking, and other chronic diseases, complication disease.
 - b. If you are over 35 years old and heavier than common weight.
 - c. Women in pregnant or in breastng period.
- 11) Please stop exercising immediately and consult your doctor when you feel giddy, surfeit, thorax ache or other symptoms.
- 12) Please drink adequate water after taking exercises on our treadmill for more than 20 minutes.

Warning: Now here we suggest that you should consult with your physician or health professional before starting your workout, especially for the age up to 35 old or once-health problem people. We take no responsible for any troubles or hurts if you don't following our specification. Treadmill will be carefully assembled and covered the motor shield, then connect to the power.

ASSEMBLY INSTRUCTIONS

When you open the carton, you will find the below spare parts:

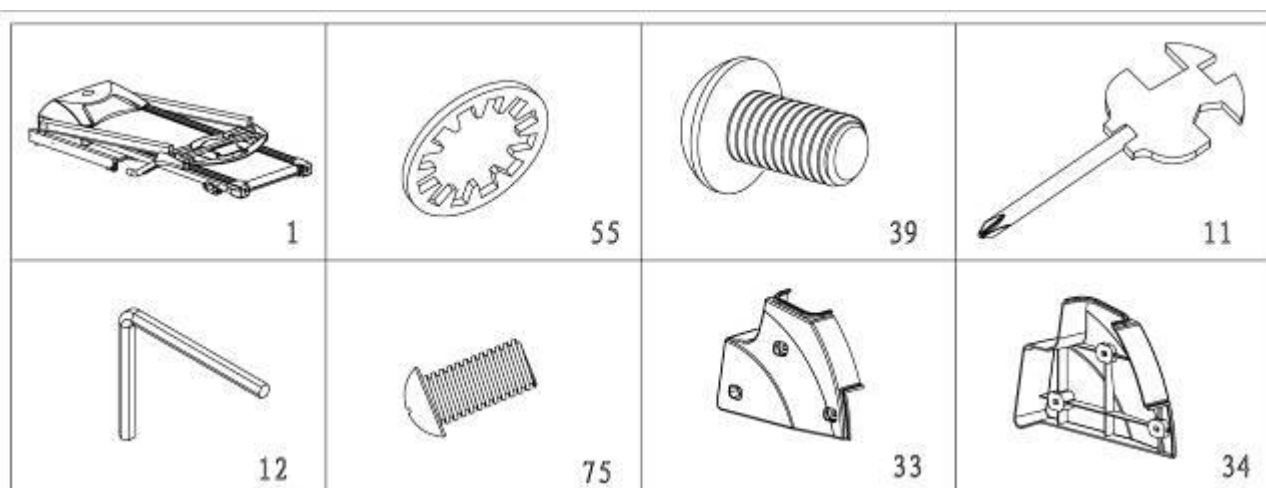

Parts List:

NO.	DES.	Specification	Nos.	NO.	DES.	Specification	Nos.
1	Main Frame		1	55	washer	8	8
39	Allen	M8*15	8	12	5# Allen Wrench	5mm	1
11	Wrench w/screw driver	S=13、 14、 15	1	75	Bolt with washer	M5*12	6
33	Left Upright Tube Cover		1	34	Right Upright Tube cover		1

Assembly tools:

5#Allen wrench 5mm 1pcs,

Wrench with screw driver S=13、 14、 15 1pcs

Notice: Do not get through power before complete assembly

Step 1:

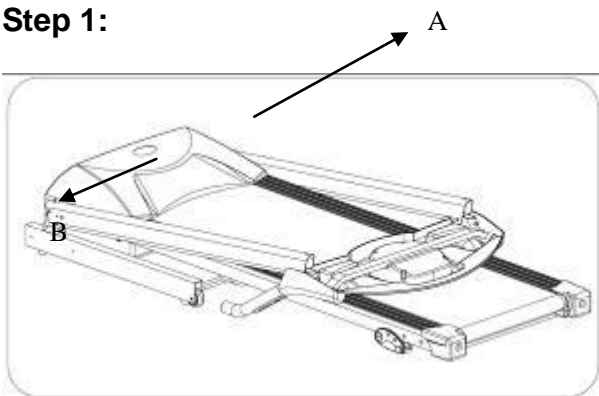

Open the carton, get out the above spare parts, and put the Main Frame on the level ground.

Step 2:



Lift up the Computer A and Upright tube B with the arrow direction.

Notice: When you lift up A and B, make sure do not press the wires inside the upright tubes; Hold the upright tubes and computer by hand to prevent any accident.

Step 3:

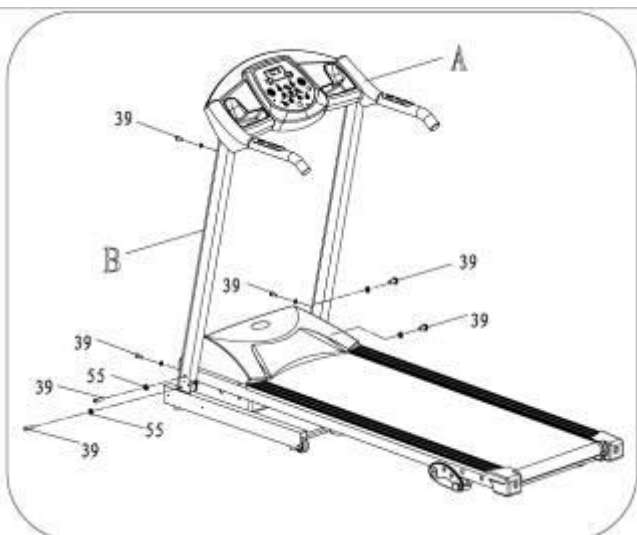

Fix the upright tube(B) and console tube(A) to the main frame with M8*15 allen (39) and washer (55) by using 5# Allen wrench(12).

Notice: Support the Upright Tube with hand to avoid falling down.

Step 4 :

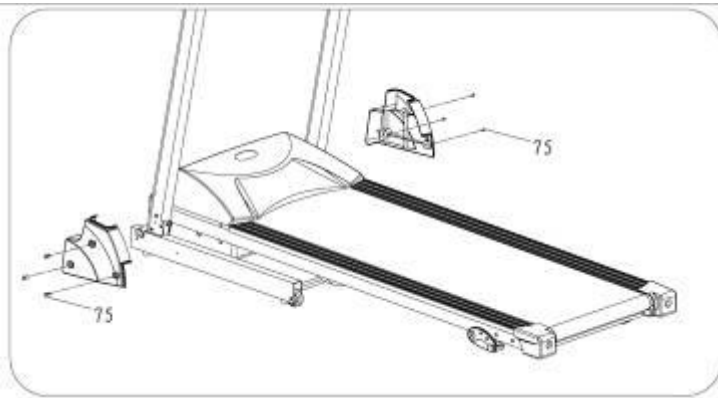

Fix the Left & Right Upright Tube Cover(33,34) to the base frame with bolt M5*12(75) by using Wrench w/ screw driver.

ATTENTION: Please confirm complete assembly as the require above and lock all the bolt. Do the following operation after checking everything is OK. Before you use the treadmill, please read the instruction carefully.

FOLDING INSTRUCTIONS

Pulling Up:

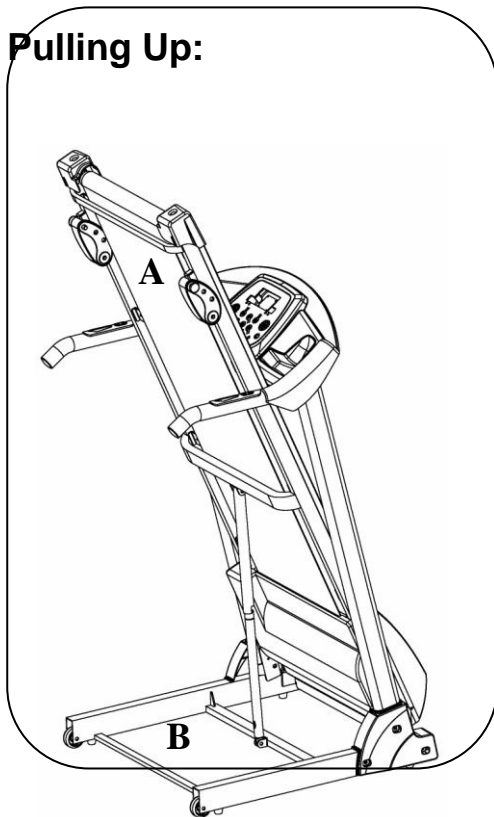

Put your hand on A position, then lift up the base frame till hearing the sound that the air pressure bar B is locked into the tube.

Pulling Down:

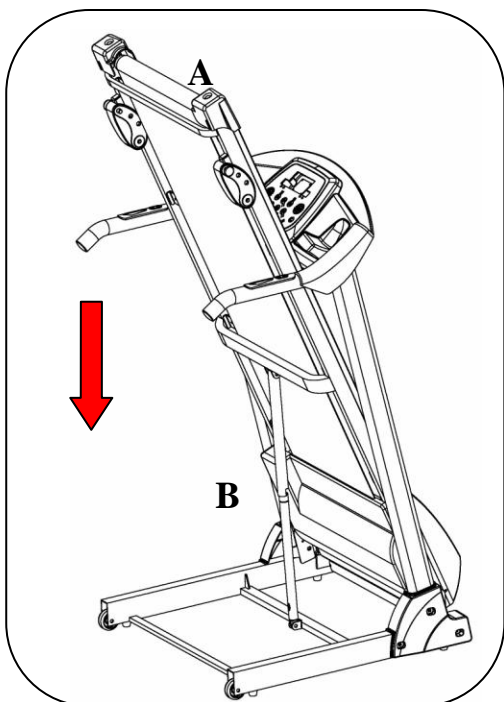

Support place A with one hand, then kick the air pressure bar at the position B, press the base frame, then it will fall down automatically (Please keep anybody and any pet away the machine when it is falling down)

TECHNICAL PARAMETER

Set up size(mm)	1580*680*1200mm	Voltage	As per country
Folding size(mm)	715*680*1530MM	Output:	As per country
Running surface(mm)	1220*400	Input:	As per country
		Speed	0.8-12KM/H or 0.8—6KM/H
Max. User Weight	120KG		
Display	SPEED TIME DISTANCE CALORIES PULSE		

GROUNDING METHODS

This product must be grounded. If it should malfunction or breakdown, grounding provides a path of least resistance for electric current to reduce the risk of electric shock. This product is equipped with a cord having an equipment-grounding conductor and a grounding plug. The plug must be plugged into an appropriate outlet that is properly installed and grounded in accordance with all local codes and ordinances.

DANGER – Improper connection of the equipment-grounding conductor can result in a risk of electric shock. Check with a qualified electrician or serviceman if you are in doubt as to whether the product is properly grounded. Do not modify the plug provided with the product – if it will not fit the outlet, have a proper outlet installed by a qualified electrician. This product is for use on a nominal voltage circuit and has a grounding plug that looks like the plug illustrated in sketch A in following figure. Make that the product is connected to an outlet having the same configuration as the plug. No adapter should be used with this product.

OPERATION GUIDE



WINDOW DISPLAY:

1. " speed " window: Display the speed, the speed range is 0.8--12km/h or 0.8--6km/h, 1 grid means 1 km/h.
When setting programmes, show P1-P9, when setting mode, show H1-H3.
2. " time" window: Display running time. Display the exercise time positive direction clock from 0:00-99:59, when count to 99:59, the machine will stop smoothly and show ' End ', then enter into initial situation after 5 seconds; When count down, it will show from the setting time to 0:00, when down to 0:00, the machine will stop smoothly and show ' End ', and will enter into the initial situation.
3. " distance" window: Display the running distance, Display the exercise time positive direction clock from 0:00-99:9, when up to 99.9, it will count again from 0; When count down, it will show from setting data to 0; When down to 0, the machine will stop smoothly and show ' End ', enter into the initial situation after 5 seconds.
4. " calories" window: Display runner's calories worked out. it will count from 0 to 999, when up to 999, it will count again from 0; when count down, it will count from the setting data to 0, when down to 0, the machine will stop smoothly and show ' End ', and enter into the situation waiting for operation after 5 seconds.
5. " pulse" window: Display the runner heart beat. When the runner holds handle pulse with two hands, the system can calculate the runner's heart beat and show in this window, the range is 50-200 beats/min (this data is just for reference, can not be as the medical data).

BUTTON FUNCTION:

1. " Program " button: Under initial situation, press this button to choose the program from "0.8"、

“ P1-P2-P3-P4-P5-P6-P7-P8-P9” 9 programs; 0.8 is the system default running mode, “P1-P9” are pre-set programs.

2. “ MODE ” button: Press this button to choose circlely “0.8”, “H1”, “ H2 ”, “H3” (0.8 is the system default running mode, “H1” is time counting down mode, “ H2 ” is distance counting down mode, “ H3 ” is calories counting down mode). When setting each mode, you can press speed +/- and incline +/- to set the data, press “ START” to start the machine

3. “ START ” button: When getting through the power and safety key attached, press this button at any time to start the machine.

4. “ STOP ” button: When the machine is running, press this button to stop any time and all the data will be initial data.

5. “ SPEED +”, “ SPEED –” button: Under initial situation, set the data with this button. When the machine is running, press the button to adjust the speed, 0.1 KM at each press, when press the button over 0.5 seconds, the speed will be up or down continually

6.”SPEED: 5,8,12” are quick buttons of speed range 0.8-12KM/H, you can choose speed 5, 8, 12 quickly by pressing quick buttons. ”SPEED: 2,4,6” are quick buttons of speed range 0.8-6KM/H, you can choose speed 2, 4, 6 quickly by pressing quick buttons.

7.SPEED SWTICH:

Under initial situation with safety key on the position, press “SPEED+/-” simultaneously and hold on for 5 seconds, the buzzer will make “B1” sound and the speed window will show the speed “12.0 (0.8--12km/h) ” or “6.0 (0.8--6km/h) ”.

The switch will not achieve under other situation.

START-UP QUICKLY(MANUAL)

1. Open the power switch, attach the magnet end of the safety pulling rope to the computer.

2. Press STATR/STOP button, the system will enter into 3 seconds count down, the buzzer will make sound and the time window display count down, the speed will run 0.8km/hour after 3 seconds.

3. After start-up, you can use “SPEED+”, “SPEED -” or speed quick buttons to adjust the speed up or down.

THE OPERATION OF EXERCISE PROCESS:

1. Press speed-down will reduce the running speed.

2. Press speed-up will increase the running speed.

3. Press speed quick buttons can adjust the speed to correspondent speed.

4. Press the stop button will stop the machine.

5. Holding the handle pulse with two hands about 5 seconds will show the pulse data.

MANUAL MODE:

1. If you do not make any setting and press START button directly, the treadmill will start to run from the speed 0.8km/h. The other windows will start to count from positive direction from windows default, press “SPEED+”, “SPEED-” change the speed.

2. set up the Time, press “MODE” button to enter into time count down H1, the TIME window will display“10 : 00” and glittering. Press “SPEED+”, “SPEED-” to set up the time what you need. The setting range is 5:00-99:00.

3.In Time setting mode, press “ MODE “ button to enter into distance count down H2, the DISTANCE

window will display “1.0” and glittering. Press “SPEED+”, “SPEED-” to set up the distance what you need. The setting range is 0.5—99.9.

4. In distance setting mode, press “MODE” button to enter into calories count down H3, the CAL window will display “50’ and glittering. Press “SPEED+”, “SPEED-” to set up the calories what you need. The setting range is 10-999.

5. When setting is finished, press “START” button to start up, the treadmill will run after 3 seconds, press “SPEED+”, “SPEED-” to adjust the speed; press the STOP, the treadmill will stop.

INNER INSTALL PROGRAM

Press “PROGRAM” button SPEED window will display P1-P9 to choose the program you like. Setting of running time, then the TIME window display glittering. Display the advance setting time 10:00, press “SPEED+”, “SPEED-” to set up the exercise time what you need. Press “START” button to start the inner install program, the inner install program is divided into 10 sect. Each exercise time=the setting time/10. When the system enter into the next sect, it will make 3 sound “B—B—” and the speed will be changed according to the setting program, then press “SPEED+”, “SPEED-” to change the SPEED, When the program enter next sect it will come back to the current speed, After finishing one program, the system will make 6 sound “B—B—” and display “END” to stop slowly, It will enter into initial situation after stopped completely in 5 seconds..

PROGRAM EXERCISE CHART

Each program will divide into 10 grade for the exercise time and each time sect has the speed accordingly.

Program exercise chart for speed range 0.8-12KM/H

PROGRAM \ TIME		TIME INTERVAL= setting time/10									
		1	2	3	4	5	6	7	8	9	10
P1	SPEED	3	3	6	5	5	5	4	4	4	3
P2	SPEED	3	3	4	4	5	5	5	6	6	4
P3	SPEED	3	3	5	6	7	8	6	4	3	3
P4	SPEED	3	6	6	6	8	8	8	3	3	3
P5	SPEED	2	5	6	7	8	8	7	7	3	3
P6	SPEED	2	10	10	8	8	7	6	3	2	2
P7	SPEED	3	4	5	6	7	8	7	6	4	3
P8	SPEED	3	8	6	9	8	8	8	3	10	3
P9	SPEED	2	4	6	8	8	8	7	7	3	3

Program exercise chart for speed range 0.8-6KM/H

PROGRAM \ TIME		TIME INTERVAL= setting time/10									
		1	2	3	4	5	6	7	8	9	10
P1	SPEED	3	3	6	5	5	5	4	4	4	3
P2	SPEED	3	3	4	4	5	5	5	6	6	4
P3	SPEED	3	3	5	6	4	5	6	4	3	3
P4	SPEED	3	6	6	6	5	5	4	3	3	3
P5	SPEED	2	5	6	5	6	6	5	4	3	3

P6	SPEED	2	5	5	4	4	3	6	3	2	2
P7	SPEED	3	4	5	6	5	4	5	6	4	3
P8	SPEED	3	5	6	5	4	3	5	3	6	3
P9	SPEED	2	4	6	5	5	4	5	6	3	3

RANGE OF PROGRAM

	Initial	Initial Data	Set Range	Display Range
TIME(MIN:SECOND)	0:00	10:00	5:00-99:00	0:00 - 99:59
SPEED(K/h)	0.8	0.8	0.8-12(0.8-6)	0.8-12(0.8-6)
DISTANCE(KM)	0.00	1.00	0.50-99.9	0.00 - 99.9
PULSE(hypo/min)	P	N/A	N/A	50-200
CALORIE(THERM)	0	50	10-999	0 - 999

BODY TESTER:

At the beginning state, press “ PROGRAM” continually entering FAT body fat tester, press “ MODE “ enter F-1、 F-2、 F-3、 F-4、 F-5 (F-1 SEX, F-2 AGE, F-3 HEIGHT, F-4 WEIGHT, F-5 FAT TESTER),

Press “SPEED+”、 “SPEED -” to set F-1 – F4 (refer to the following chart), after that, press “ MODE” to set F-5, grasp the hand pulse, the window will display your body quality index after 3 seconds. The body quality index is to test the relation between height and weight. The body FAT suits for any male and female, to adjust the weight according it together with other body quality index. The idea FAT should be 20-25, if under 19, it means too thin. If between 25 and 29, it means overweight, if over 30, it means obesity. (The data is just for reference, can not be as medicinal data)

F-1	Sex	01 male	02 female
F-2	Age	10-----99	
F-3	Hight	100----200	
F-4	Weight	20-----150	
F-5	FAT	≤19	Underweight
	FAT	=(20---25)	Normalweight
	FAT	=(26---29)	Overweight
	FAT	≥30	Obesity

SAFETY LOCK FUNCTION:

Pull out the safety pulling rope, then the treadmill will stop immediately. All the windows display“———”, the buzzer will make 3 sound “B—B—”,now the treadmill must stop. Attach the magnet end of the safety pulling rope to the computer, the treadmill will be at the beginning of running.

POWER SAVE FUNCTION:

The system is with saving on power function, at the state of waiting for operation, if without any operate, the saving on power function will be available after 10 mins, the display will be closed up. You can press any button to wake up the display.

MP3 FUNCTION(OPTIONAL)

When the power on, Contacting the external MP3 equipment, the computer will play. The voice is adjustable from the external MP3 equipment, the voice should be adjusted on the proper section to protect the computer loudhailer.

TURN OFF:

Turn off the power: You can turn off the power to stop the treadmill, it won't be damaged at any time.

CAUTION:

1. We recommend that you maintain a slow speed at the beginning of a session and hold on to the handrails until you become comfortable and familiar with the treadmill.
2. Attach the magnet end of the safety pulling rope to the computer and also attach the clip of the safety pulling rope to your clothing.

To end your workout safely, press the PAUSE button or pull out the safety pulling rope, then the treadmill will stop immediately.

EXERCISE INSTRUCTIONS

WARM UP STAGE

If you are over 35 years old, or not very healthy, also it's your first time exercise, please consult with your doctor or professional person.

Before you use the motorized treadmill, please learn how to control the machine, know well how to start, stop, adjust the speed and so on, don't stand on the machine at this time. After that, you can use the machine. Stand on anti-slip pad both sides and handle the handle bar with your both hands. Keep the machine at the low speed about 1.6~3.2 km/h, then test the running machine by one foot, after get used to the speed, then you can run on the machine and you can add the speed between 3 and 5 km/h. Keep the speed about 10 minutes, then stop the machine.

EXERCISE STAGE

Learn how to adjust the speed and incline before using. Walk about 1 km at stable velocity and write down the time, it will take you about 15-25 minutes. If walk at 4.8 km/h, it will take you about 12 minutes in 1 km. If you feel comfortable at the stable velocity, you can add the speed and incline, after 30 minutes, you can have good exercise. At this stage, you can not add the speed or incline too much at one time, it can keep you feel comfortable.

EXERCISE INTENSITY

Warm up at the speed 4.8 km/h in 2 minutes, then add the speed to 5.3 km/h and keep walking in 2 minutes, then add to 5.8km/h and walk in 2 minutes. After that, add up 0.3 km/h in each 2 minutes, until rapid breath but not feel comfortable

Calorie burning---the best effective way

Warm-up for 5mints by the velocity:4-4.8KM/H, then slowly increase the speed by

0.3KM/H/2Mints ,until up to the stable speed which you feel is comfortable for 45Mints.For improving the intensity of movement, you can maintain the speed during 1H of TV program, then increase the speed by 0.3KM/H each Advertisement interval time, after that return to the original speed . You can acquaint the best efficiency of workout for calorie burning during the advertisement time and subsequent heart frequency increasing time. Finally , you should slow down the speed step by step for 4Mints.

EXERCISE FREQUENCY

The cycle time: 3-5times/Week, 15-60mints/Times.Make up the schedule of workout scientific, not only for your hobby.

You can control the running intensity through adjusting the velocity and incline of treadmill. We suggest that you don't set the incline at first; improve the incline is the effective way to strengthen the exercise's intensity.

Consult with your physician or health professional before starting your workout. The professional people can help you make up the suitable exercise time-chart according to your age and health condition, determine the velocity of movement, the intensity of exercise. Please stop at once, If you feel chest tightness, chest pain, irregular heart beat, breath difficulty, dizziness or other discomfort during exercise. You should consult with your physician or health professional as keep going.

You can choose the normal walking speed or the jogging speed ,if you always take workout with treadmill.

If you don't have enough experiences or confirm the testing velocity ,you can follow the instruction :

- Speed 1-3.0KM/H not well physical
- Speed 3.0-4.5KM/H less movement and workout
- Speed 4.5-6.0KM/H normal walking
- Speed 6.0-7.5KM/H Fast walking
- Speed 7.5-9.0KM/H Jogging
- Speed 9.0-12.0KM/H intermediate speed walking
- Speed 12.0-14.5M/H well experiences of running
- Speed 14.5-16.0KM/H excellent runner

Attention: The velocity of movement $\leq 6\text{KM/H}$, **the normal walking**; The velocity of movement $\geq 8.0\text{KM/H}$,**the runner**.

MAINTENANCE INSTRUCTIONS

Warning: Unplug the treadmill before cleaning or repairing the treadmill.

Clean: Cleaning all the time will prolong the treadmill using life.

Get rid of the dust all the time to keep the components clean. Clean the two exposed sides of the running belts will avoid the dust getting under the belt. Keep the running shoes clean otherwise the dirt on the shoes will wear the runningboard and running belts out. Clean the surface of the running belt with clean? rags. Be aware of the water spill on the electrical parts or the running belts.

Warning: Plug the treadmill at the wall before removing the motor cover.

RUNNING BELTS AND TREADMILL LUBRICANT

We have put the lubricant on the running board and running belt. The friction between the running BELTS and running board affects a lot to the life and function of the treadmill, therefore, we suggest checking the board regularly. Should there be any wear on the board, please contact our service center.

We recommend lubrication of the deck according to the following timetable:

a) Light user (less than 3 hours/ week) triweekly

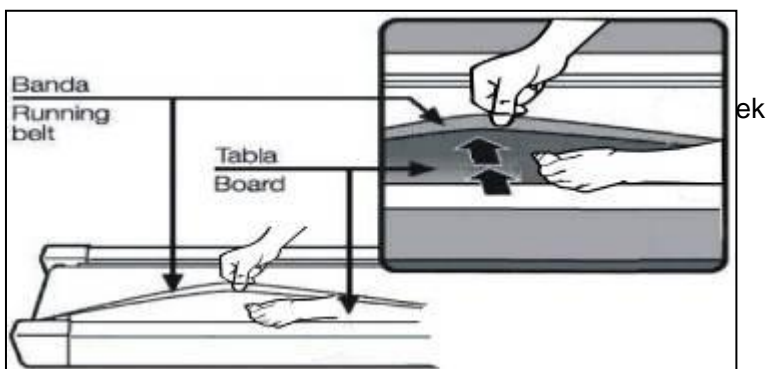

We suggest you purchase the lubricant from our local distributors or contact our company directly.
Note: For other maintenance, please get a specialized person to operate.

- 1 . To have a better maintenance over the treadmill and prolong its life, we suggest you power off for ten minutes in every two hours.
- 2 . Loose belt will result in sliding while running, while too tight shall decrease the motor performance and create more friction between the roller and running belts. The most suitable tightness of the belts would be: the belts can be pulled out 50-75mm away from the running boards.

CENTER THE RUNNING BELT:

1. Put the treadmill on a flat ground and have the treadmill run at 6-8 km/hour to check if it drifts

2. If it drifts to the right side, turn adjusting bolts on right side 1/4 circle clockwise, check if it drifts. Repeat the steps above until it centers, see picture A.

3. If it drifts to the left side, turn adjusting bolts on left clockwise, check if it drifts. Repeat the steps above until it centers, see picture B.

4. The running belts will loosen in a certain amount of time. So to solve this problem, turn adjusting bolts on both side 1/4 circle clockwise, check if it drifts. Repeat the steps above until it centers, see picture C.

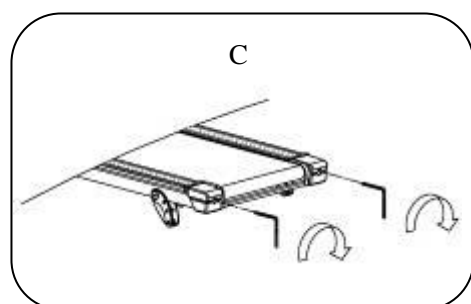
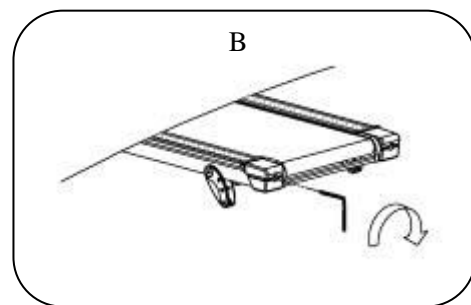
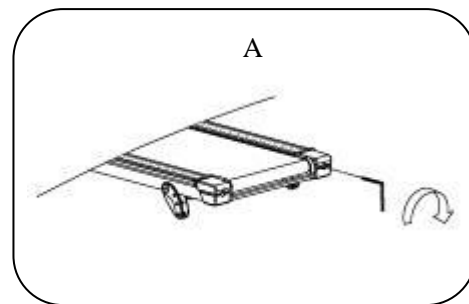

EXPLODED DRAWING

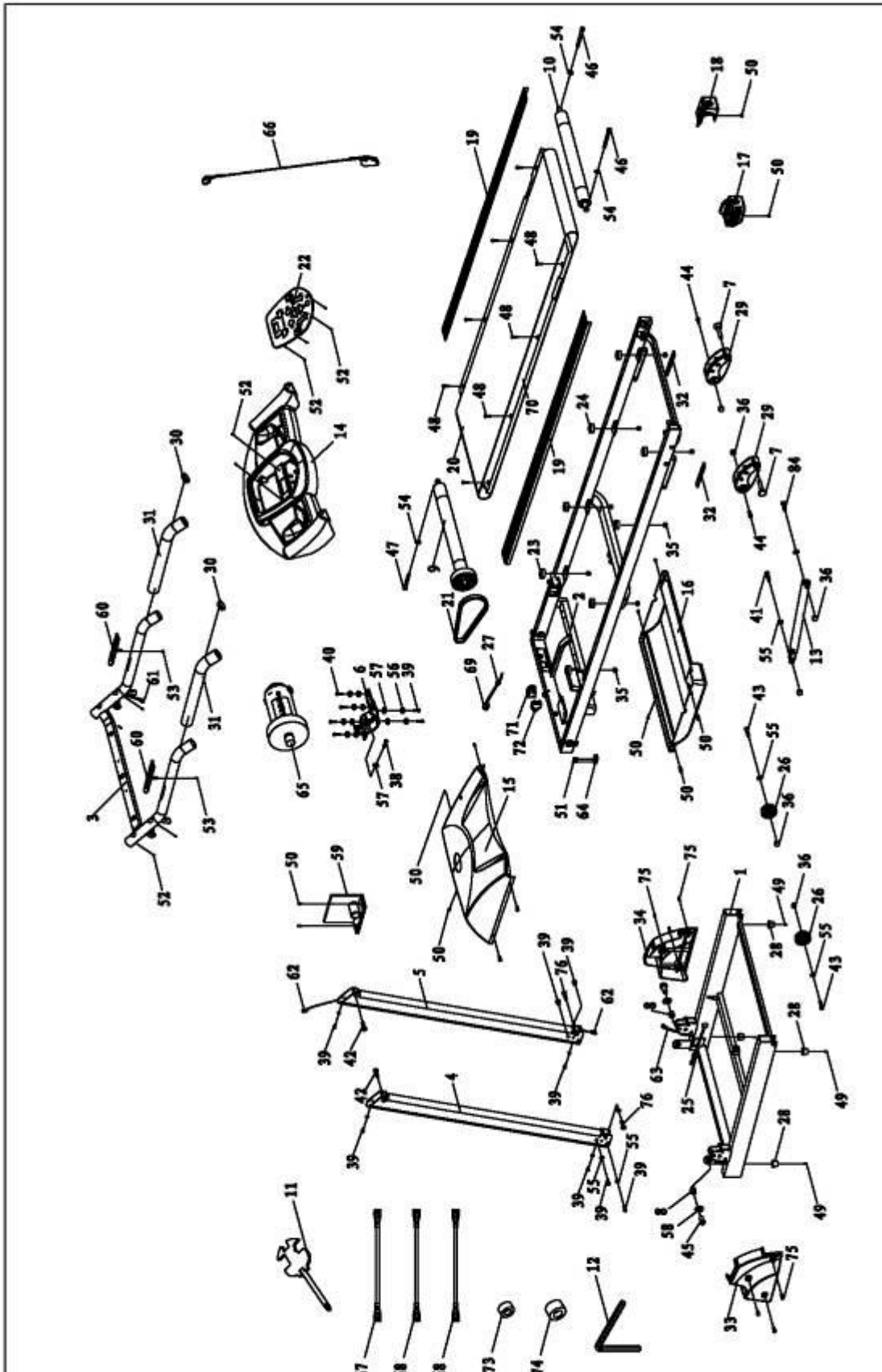

PARTS LIST

1	Base Frame		1	40	Allen	M8*20	4
2	Main Frame		1	41	Allen	M8*30	1
3	Computer Bracket		1	42	Allen	M8*35	2
4	Left Upright		1	43	Allen	M8*40	2
5	Right Upright		1	44	Allen	M8*45	2
6	Motor Bracket		1	45	Allen	M10*30	2
7	Fixing pin		2	46	Allen	M6*55	2
8	Turning Bushing		2	47	Allen	M6*45	1
9	Front Roller		1	48	Allen	M6*30	8
10	Rear Roller		1	49	Bolt	M5*16	4
11	Wrench w/ screw driver	S=13、14、15	1	50	Bolt	M5*8	15
12	5# Allen Wrench	5mm	1	51	Bolt	S T2.9*8	2
13	Cylinder		1	52	Bolt	ST4.2*12	8
14	Console top cover		1	53	Bolt	ST4.2*25	2
15	Motor top cover		1	54	Washer	6	3
16	Motor bottom cover		1	55	Washer	8	12
17	Left rear cover		1	56	Washer	8	6
18	Right rear cover		1	57	Flat washer C	8	7
19	Side rail		2	58	Big washer C	φ10*φ26*2.0	2
20	Running belt		1	59	Control board		1
21	Motor belt		1	60	Handpulse panel		2
22	Console panel		1	61	Console upper wire		1
23	Black cushion		4	62	Console middle wire		1
24	Blue cushion		4	63	Console lower wire		1
25	Ring protecting wire plug		2	64	Speed sensor		1
26	Moving wheel		2	65	DC Motor		1
27	Power wire buckle		1	66	Safety accessory		1
28	Foot pad		4	67	AC single line	Blue	2
29	Adjustable foot pad		2	68	AC single line	Brown	3
30	End cap		2	69	Power wire		1
31	Foam		2	70	Running board		1
32	EVA cushion		3	71	Square switch		1
33	Left upright tube cover		1	72	Overload Protector		1
34	Right upright tube cover		1	73	Magnetic ring		1
35	Bolt	M6	8	74	Magnetic core		1
36	Bolt	M8	6	75	Bolt	M5*12	6
37	Bolt	M8	7	76	Bolt	M8*40	2
38	Bolt	M8*35	1				
39	Allen	M8*15	10				

TROUBLE SHOOTING

- 1、 Probable reason for computer not workable after power start: The wire from computer to bottom control board didn't connected well or the transformer was burnt out. Check the each wire from computer to control board, make sure they are connected well. If the wire is destroyed , change it. If the above can not settle the problem, try to change a good transformer.
- 2、 E01: Message failure. Probable reason: The wires from computer and bottom control board did not connect well, please check each wire. If the wire was destroyed, change a good one.
- 3、 E02: Burst clash. Check the power is right, if not, use correct power to test; Check if the bottom control was burnt out, change a good one; reconnect the motor wire.
- 4、 E03: No sensor signal. Check if all sensor wire are good, if damaged, change a good one. If not works, check if the speed sensor is ok, if damaged, change the speed sensor. If still not works, check if the motor wire connect well or need to chagne motor.
- 5、 E05: Current overload protecting. Over rated loaded or the motor is stuck, cause excessive current, machine will start self-protecting system. Adjust the machine and restart; Check if the motor has noise from motor or if the motor / bottom control board were burnt out, if burnt out, change good motor and bottom control; Use right voltage.
- 6、 If the motor can not work after pressing START button, the probable reason: the motor wire is broken; the safety pipe is broken or fell; motor wire is not conneted well; IGBT on bottom control board is burnt out. Test the above reasons and change the relevant part.