



hattrick

QUADRO MOTORIZED TREADMILL USER MANUAL



Special tips:

Before installation and operation, please read this operation manual carefully and save this manual for future reference.

Table of Contents

CONTENT	PAGE
1、 Warranty	1
2、 Tips for Safety	2
3、 Packing Details	3
4、 Explosive View	4
5、 Part List	5
6、 Treadmill Structure	6
7、 Installation	7
8、 Use Instructions	9
9、 Guides for Console Operation	10
10、 Detailed Instructions	13
11、 Maintenance	15
12、 Guides for Malfunction	17

Acknowledgement

Thank you for purchasing this item which can improve your health.

1、 Warranty

- We make sure that this item is made of high-quality materials.
- In normal use, we will take charge of maintenance if any problem occurs.
- If the item you purchased meets problems as follows, the manufacturer's warranty is not effective:
 - Damage caused by external reasons
 - Don't use original manufacturer's spare parts
 - Improper handling by yourself
 - Operate against user manual
- For easy-wear parts, such as belt, we don't provide maintenance and replacement for normal use.
- This warranty is only valid for home use, but is not suitable for gym or other professional exercise.
- If you want to purchase spare parts, please contact our services and provide this manual.

2、 Tips for Safety

We take much concern on safety when we are designing and producing this item. However, in case of emergency, please pay attention to following tips. We don't assume responsibility if any accident caused by improper operation..

- According to your body condition, please exercise properly. Overload or improper exercise will damage your health.
- While running, you should dress properly. Don't dress too loosely in case your clothes will be entangled by the machine .And please wear sport shoes. In order to avoid unnecessary injury, please don't let your children or pets play near the machine.
- This item is not suitable for children. For patients or the disabled, please use the machine under the guides of their doctors or guardians.
- Don't use this machine outdoor, high-humidity condition or in the sun.
- Please power off and pull the plug when the machine is not in use.
- This machine is for home use, but not suitable for professional exercise or testing and medical purposes.
- The displayed heart rate is for reference, not for medical use.
- If power wire is broken, please ask the manufacturer or professional services to replace it in case of danger.
- Please check all the parts before use. Make sure that all the screws and nuts are fastened.

- Please place the item on the clean, flat and solid floor. Make sure there is nothing sharp, no source of water or hear around the machine.
- Please stop exercising immediately and consult your doctor or fitness coach if you're feel giddy, surfeit, thorax ache or other symptoms.
- Hands shall avoid all running parts. Don't put your hands or feet under the running belt.
- This item is only for one person to use!
- Please use original manufacturer's spare parts and don't replace them yourself.



3、Packing Details

Warning: Carefully install the product, avoid making any damage.





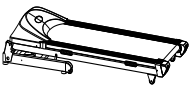
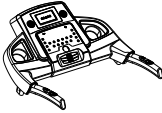

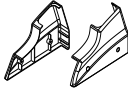
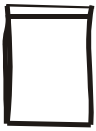
Notice: 1) Carefully read instructions before installation, operate in accordance with procedures.

2) Remove all paper boxes and foams

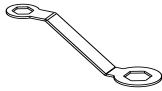
3) Check all the following components. If there are missing or problematic parts, please contact our services.

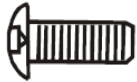
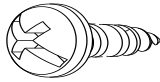
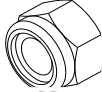
				
Frame	Meter	Meter pillar	Decorative cover	Hardware bag

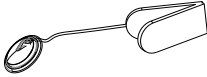
Hardware bag

		
Multi-wrench 1 pcs	Homemade wrench 1 pcs	Umbrella-type allen screw M8*50 4pcs
		
Umbrella-type allen screw M8*15 8pcs	Umbrella-type cross tapping screw M4.2*15 4pcs	Nut 4pcs
		
Washer 12pcs	Safety key 1pcs	MP3 connector 1pcs
		
Lubricant 1pcs		

4、 Explosive View:

These are all the components used in installation. All components are listed in the following form.

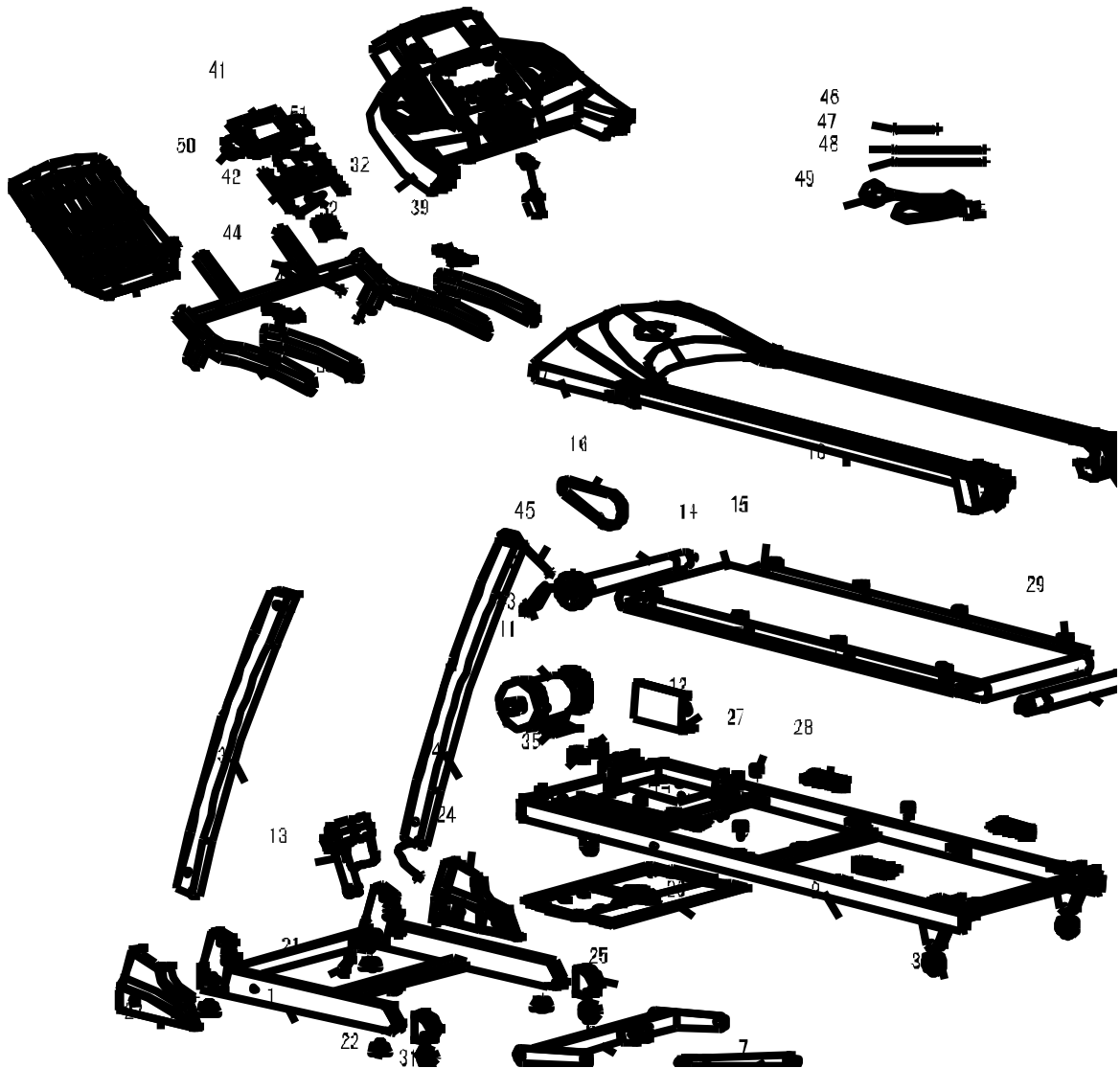

5、 Part List

No.	Description	Quantity	No.	Component	Quantity
1	Base frame	1	29	Locating pad of footplate	8
2	Main frame	1	30	Rubber transporting wheel	2
3	Left meter pillar	1	31	Transporting wheel	2
4	Right meter pillar	1	32	Upper cover of the meter	1
5	Meter frame	1	33	Under cover of the meter	1
6	Incline frame	1	34	Power switch	1
7	Pressure stick	1	35	Overload protector	1
8	Motor stator	1	36	Reed pipe for safety key	1
9	Front roller	1	37	Safety key	1
10	Back roller	1	38	Sponge sheath on handlebars	2
11	Motor	1	39	Hand heart rate and speed buttons	1
12	PCB	1	40	Hand heart rate and incline buttons	1
13	Incline motor	1	41	Upper control panel	1
14	Running belt	1	42	Key board	1
15	Running board	1	43	Speed sensor wire	1
16	Multislot belt	1	44	Upper communication line	1
17	Motor cover	1	45	Under communication line	1
18	Footplate	2	46	Red connecting line	1
19	Left back cover	1	47	Red connecting line	1
20	Right back cover	1	48	Green connecting line	1
21	Connecting part of base frame	1	49	Power wire	1
22	Adjustable foot pad	5	50	Speaker	2
23	Left decorative cover	1	51	MP3 module	1
24	Right decorative cover	1	52	Fan	1
25	Cover of transporting wheel	2			
26	Cover under motor	1			
27	Shock gasket	4			
28	Shock absorber	4			

6、Treadmill Structure

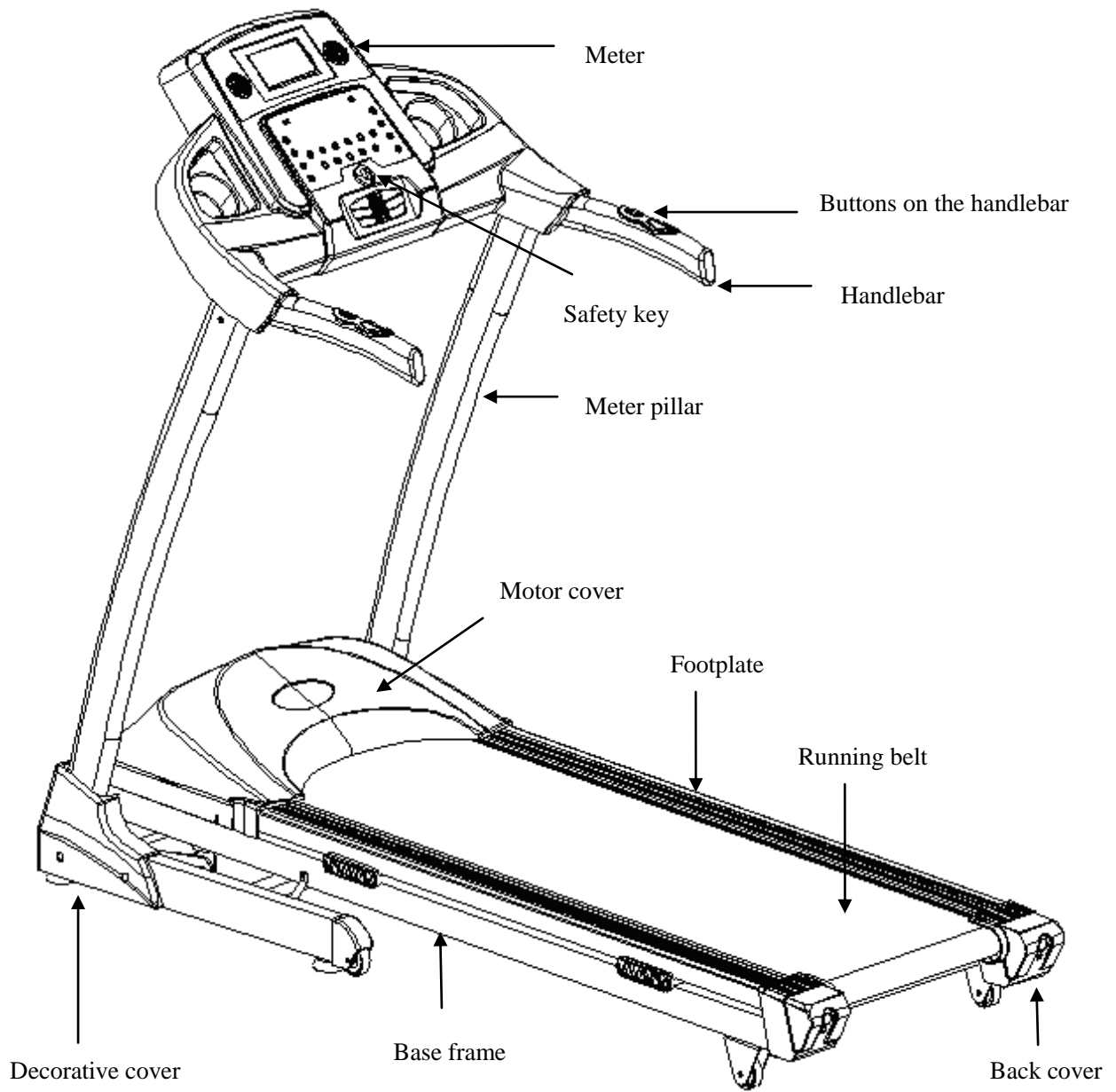

7、 Installation

Step 1: Install meter pillars

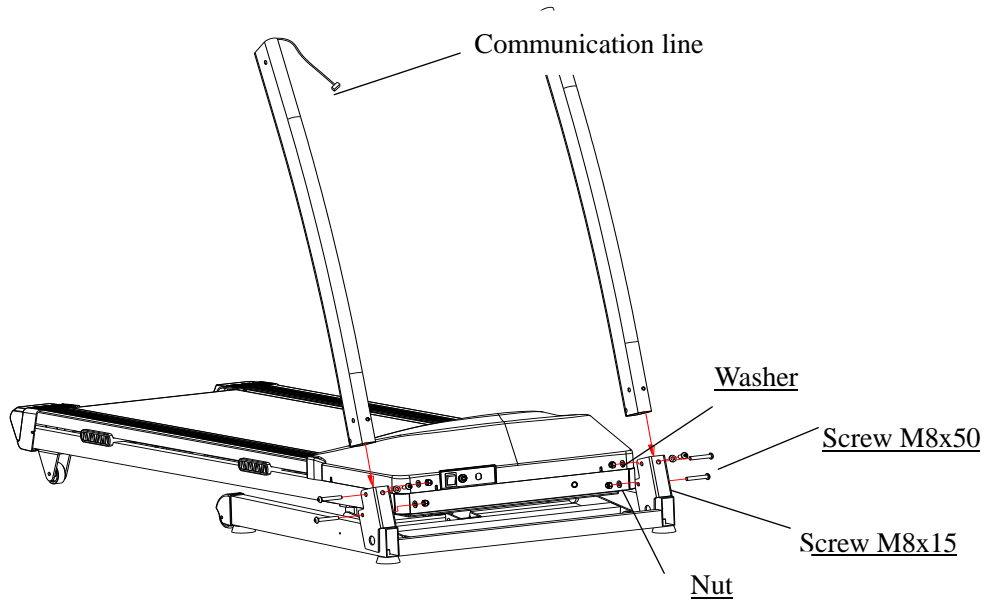

- Let the communication line pass through the right meter pillar.
- Put meter pillars on the base frame. First, use 2 Screw M8*15 and 2 washers; second, use 4 Screw M8*50, 4 washers and 4 nuts to fasten meter pillars. (Don't tighten screws at first)

Step 2: Install the meter

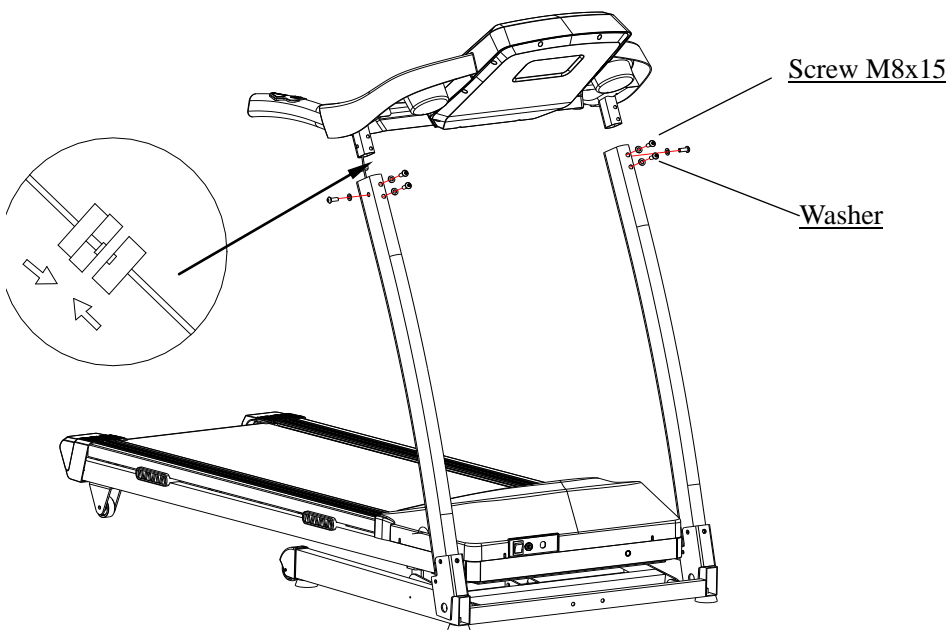

- Make sure that communication lines are connected correctly
- Put the meter on the meter pillars. Use 6 Screw M8*15 and 6 washers to fasten

the meter. (Don't tighten screws at first)

- c) Turn power on and start the machine. If all functions work well, tighten all screws in **Step 1** and **2**.

Step 3: Install decorative covers.

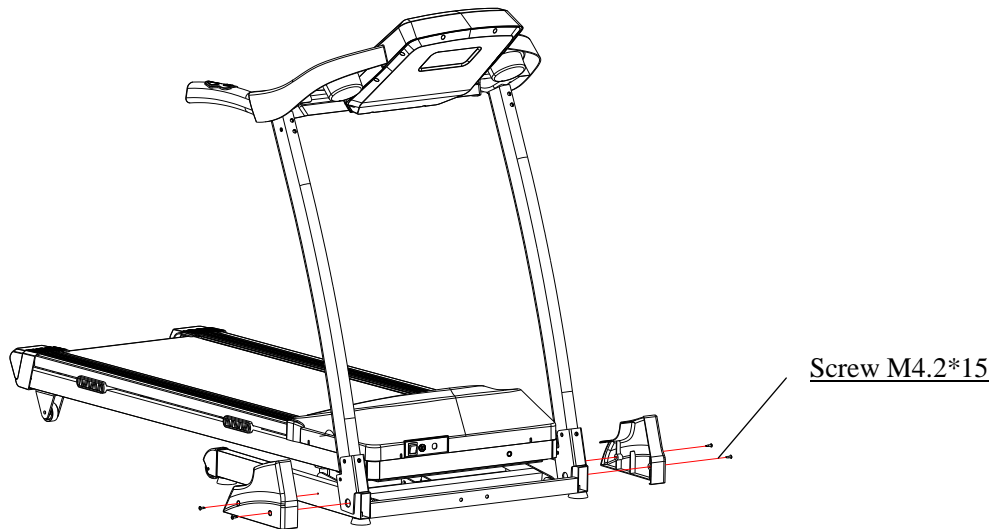

- a) Use 4 Screw M4.2*15 to fasten left and right decorative covers.

Step 4: Remove the screw in base frame

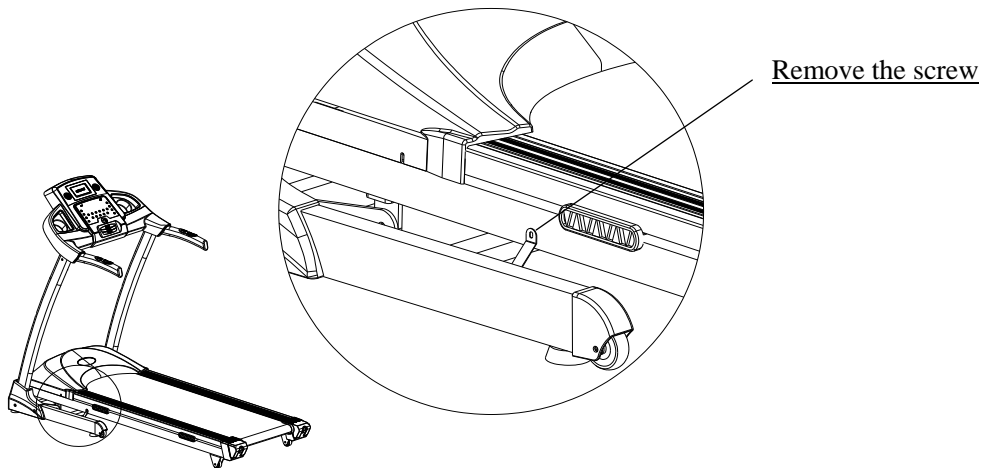

8、 Use Instructions

Power:

Insert the power plug and switch on the machine. The switch light will be on and you will hear a sound like “Di”. Then you will find the meter is on.

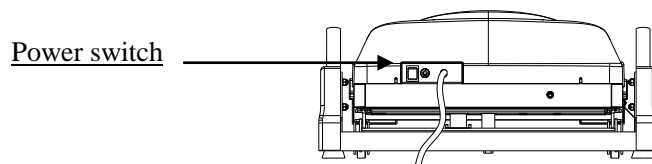

Safety key:

The machine can work only when safety key is put at the appointed position. Nip the other end of safety key to clothes. In this way, you can pull up safe key to stop the machine immediately in case of accidents. If you want to use the machine again, put safety key back.

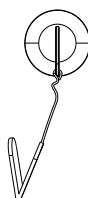

Folding instructions :

➤ Folding:

Folding the machine will save space.

Before folding, please switch off and pull up the plug.

Use hands to lift the running board until it is locked.

➤ Unfolding:

First, lift up the running board a little and step on the pressure sticker. Second pull down the running board for a while, then the running board will goes down to the ground automatically.

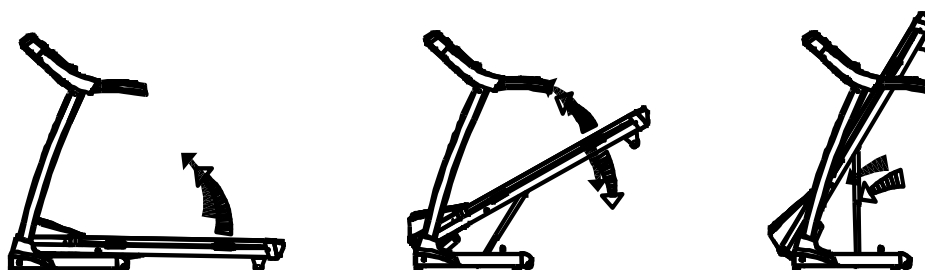



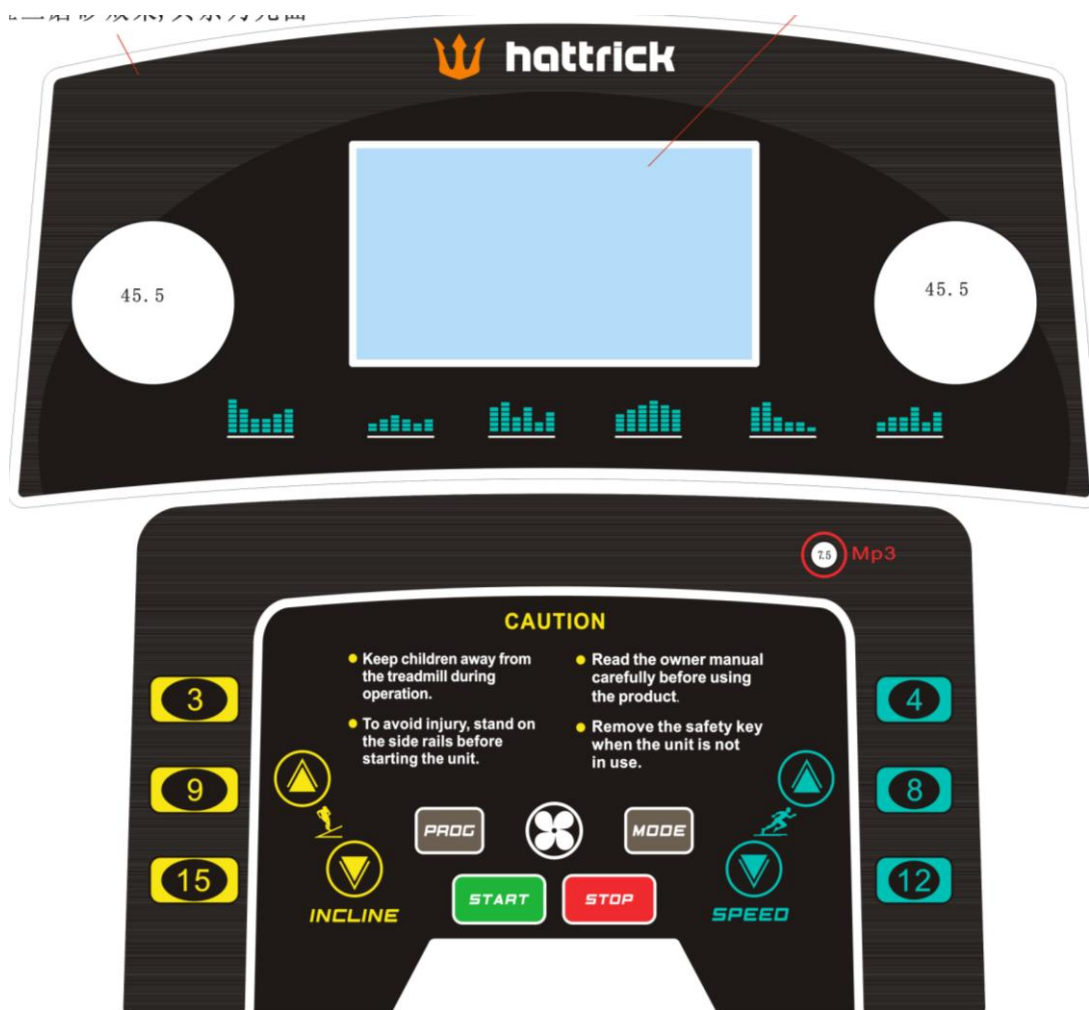

9、 Guides for Console Operation

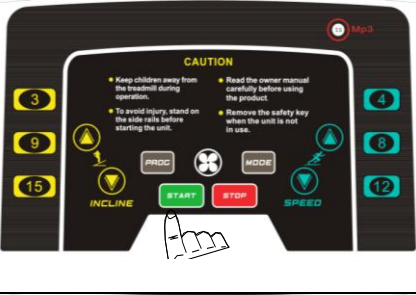
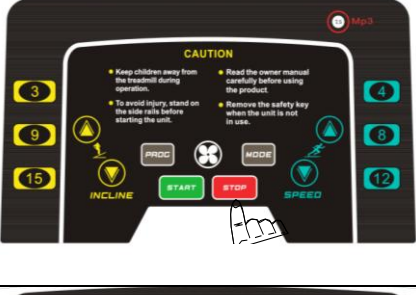

Specifications

Time	00:00-99:59 min	
Speed	1.0-16.0 km/h	
Incline	0-15%	
Distance	0.00-99.9 km	
Calories	0-999 kcal	
Heart rate	50-200 / min	
Program	Built-in program	P1-P99
	Count-down mode	Time/Distance/Calories
	User-defined program	U1—U3
	Body fat measurement	Fat
Sex	1/0 (Man/Woman)	

Panel buttons and functions

 <p>The image shows the treadmill control panel. A hand is pointing to the green 'START' button. The panel includes a 'CAUTION' warning, 'INCLINE' and 'SPEED' buttons, and a numeric keypad (3, 9, 15, 4, 8, 12). Safety instructions are displayed on the screen.</p>	<p>START button: Press “Start” button, the system will count down in 3 seconds, which displays on the screen! The machine will run at the speed of 1.0km/h.</p>
 <p>The image shows the treadmill control panel. A hand is pointing to the red 'STOP' button.</p>	<p>STOP button: Press this button to stop the running machine.</p> <p>Reset: Press “Stop” button twice continuously to reset the machine.</p>
 <p>The image shows the treadmill control panel. A hand is pointing to the 'PROG' button.</p>	<p>PROG. Button In ready condition, press “PROG” button to select programs from P1-P99. P1-P99 are built-in programs. U1-U3 are user-defined programs. FAT is body-fit program. After finish selection, press “Start” button to start the machine!</p>
 <p>The image shows the treadmill control panel. A hand is pointing to the 'MODE' button.</p>	<p>MODE button In ready condition, press “MODE” button to select from Time, Distance and Calories count-down modes. After finish selection, press “Start” button to start the machine!</p>
 <p>The image shows the treadmill control panel. A hand is pointing to the 'SPEED' buttons (up and down arrows).</p>	<p>SPEED Δ ∇ button In ready condition, buttons are used to adjust preset-data. In running condition, buttons are used to adjust speed, and the adjusting range is 0.1km/h each time. Keep pressing buttons for over 0.5 second, the speed will continuously increase or decrease.</p>

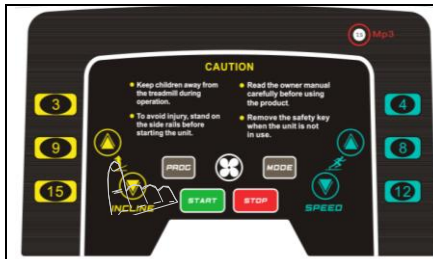

INCLINE Δ ▽ button

In ready condition, buttons are used to adjust preset-data.

In running condition, buttons are used to adjust incline, and the adjusting range is 1% each time. Keep pressing buttons for over 0.5 second, the incline will continuously increase or decrease.



SPEED direct button

In running condition, press these buttons to set the speed to be 4km/h, 8km/h and 12km/h directly.



INCLINE direct button

In running condition, press these buttons to set the incline to be 3%, 9% and 15% directly.

Screen

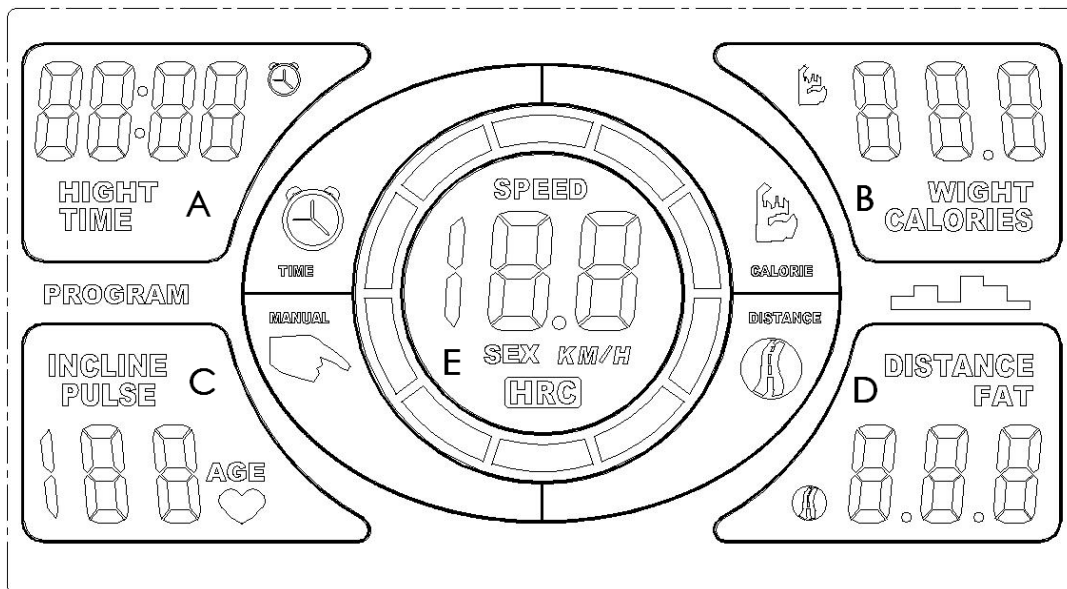

A	Display height and time
B	Display weight and calories
C	Display incline and pulse
D	Display distance and fat
E	Display speed and sex

10、 Detailed Instructions

a. Quick start (Manual mode)

1. Switch power on and put the safety key at the appointed position.
2. Press “Start” button, the system will count down in 3 seconds, which displays on the screen! The machine will run at the speed of 1.0km/h.
3. According to your needs, press “SPEED Δ or ∇ ” to change speed and press “INCLINE Δ or ∇ ” to change incline.
4. When hands are on hand heart rate sensors for 5-8 seconds, heart rate will be displayed on the screen.

b. Count-down mode:

In ready condition, press “MODE” button to select countdown modes. After finish selection and reset “Time/Distance/Calories”, press “Start” button to start the machine!

1. In “Time Mode”, the screen displays flashing “15: 00”. Then press “SPEED Δ or ∇ ” or “INCLINE Δ or ∇ ” to reset time from 05: 00—99: 00.
2. In “Distance Mode”, the screen displays flashing “1.0”. Then press “SPEED Δ or ∇ ” or “INCLINE Δ or ∇ ” to reset distance from 0.5—99.9.
3. In “Calories Mode”, the screen displays flashing “50”. Then press “SPEED Δ or ∇ ” or “INCLINE Δ or ∇ ” to reset calories from 10—999.

c. Built-in program

There are 99 built-in programs, from P1 to P99. In ready condition, press “PROG.” button to select one program from P1-P99. After that, press “MODE” button to set time from 5: 00—99: 00. Then press “START” button to start the machine.

Every built-in program is divided into 10 periods, each period lasts 1/10 of set time. During every period, press “SPEED Δ or ∇ ” to change speed and press “INCLINE Δ or ∇ ” to change incline if necessary. From one period to another, there will be a sound like “Bi” for 3 times, then speed and incline will be changed according to built-in programs. After finishing one program, there will be a sound like “Bi” for 3 times, then the machine will stop slowly and the screen will display “End”. The machine will be in ready condition in 5 seconds.

d. User-defined program

Besides 99 built-in programs, there are 3 user-defined programs for you to set your own exercise programs

Set

In ready condition, press “PROG.” button continuously to U1-U3, they are user-defined programs. After selecting U1, U2 or U3, press “MODE” to set. Press “SPEED Δ or ∇ ” to change speed and press “INCLINE Δ or ∇ ” to change incline for the first period. Then press “MODE” key to confirm the first period and set next period. After setting all 10 periods, press “START” button to start the machine.

User-defined programs will be kept in the machine forever unless you reset them.

These data will not disappear if power off.

e. Body fat measurement:

In ready condition, press “PROG.” button continuously to “FAT”. Press “MODE” button to select “HEIGHT”, “WEIGHT”, “AGE”, “SEX” and “FAT”. Press “SPEED Δ or ∇ ” or “INCLINE Δ or ∇ ” to set above data. Then press “MODE” to “FAT” screen. At this time, put your hands on the hand heart rate sensor for 5-8 seconds. Then you will see body fat displayed on the screen.

Please find out whether your weight and height fits according to the following form. (These data is only for reference, not for medical use)

F-1	SEX	1-MAN	0-WOMAN
F-2	AGE	10-99	
F-3	HEIGHT	100-220	
F-4	WEIGHT	20-150	
F-5	FAT	≤ 19	Thin
		20—25	Fit
		25—29	Overweight
		≥ 30	Obesity

f. Power saving:

When the power is on, if the machine doesn't work for 10 minutes, it will sleep and the screen will be off. Press any key to wake up the machine.

11、Maintenance

Maintain the machine

Proper maintenance can always keep the machine in good condition.

1. Do not use sand paper or solvent to clean the machine.
2. Controlling parts can not be exposed in the sun or humid environment.
3. Check and tighten all parts regularly. Replace broken parts immediately.

Adjust the running belt

The running belt is well adjusted before being packed. After a period of use, the running belt may loosen or deflect, which is normal. Then it is necessary to adjust the running belt, otherwise there will be friction damage to the running belt.

1. Tension:

- a) Keep the machine at the speed of 3km/h.
- b) Put the multi-wrench into the left adjusting screw and turn clockwise by 1/4 circle.
- c) Put the multi-wrench into the right adjusting screw and turn clockwise by 1/4 circle.
- d) If necessary, repeat Step b and c as above until the running belt runs smoothly.

Note: These four steps are available to tighten the running belt, if you need to loosen it, please turn anti-clockwise.

2. Deflection:

- a) Keep the machine at the speed of 6km/h.
- b) If the running belt deflect to the left, put the multi-wrench into the left adjusting screw and turn clockwise by 1/4 circle or put the multi-wrench into the right adjusting screw and turn anti-clockwise by 1/4 circle. (Diagram 1)
- c) If the running belt deflect to the right, put the multi-wrench into the right adjusting screw and turn clockwise by 1/4 circle or put the multi-wrench into the left adjusting screw and turn anti-clockwise by 1/4 circle. (Diagram 2)
- d) If necessary, repeat Step b and c as above until the running belt runs in the middle.

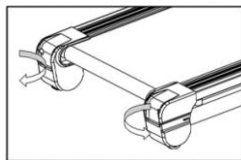

Deflect to the left (Diagram 1)

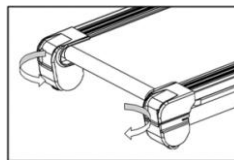

Deflect to the right (Diagram 2)

Lubricant (White bottle)

All treadmills were added lubricant before packed. However, it is still necessary to add lubricant after using the machine for 30 hours or 30 days.

How to add lubricant:

- a) Cut a small hole at the head of the lubricant bottle. Make sure that the lubricant can be shot out from the hole.
- b) Lift up the running belt and shoot the lubricant to the middle of the running board.
- c) Put down the running belt and put some pressure on the place where you add lubricant.
- d) Start the machine at the speed of 1 km/h for 1 minute.

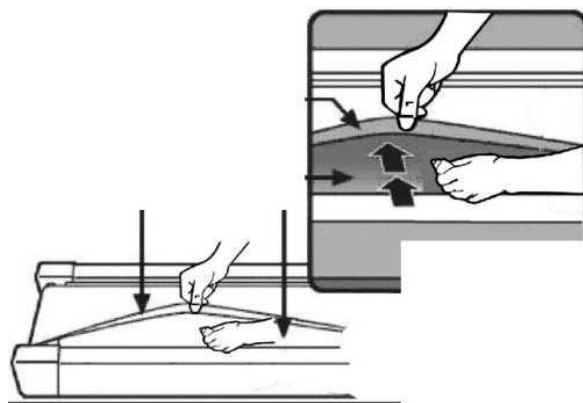

Cleaning

Clean the machine regularly to extend service life. Here are some tips for cleaning:

- Please power off and pull the plug before cleaning.
- Do not use corrosive or liquid material to clean the machine, which shall cause damage to electronic parts.
- Frequently wipe out the sweat and dust on the surface, running board or somewhere else by clean or wet cloth.
- Please clean the floor around the machine every week.

12、Guides for Malfunction

Analyzing and eliminating malfunction

Item	Malfunction	Reason	Solution
1	The machine doesn't work	The safety key is missing	Put the safety key at the right position
		The power switch is in "0" position	Turn power switch to "1"
2	The meter doesn't work	The meter and upper communication line are not correctly connected	Disassemble the meter and make sure that the meter and communication line are well connected.
		The upper communication line is broken	Replace the upper communication line!
3	E0 on the screen	No safety key	If safety key is at the right position, then check the connecting part and make sure the safety key is connected well.
4	E01 on the screen	No signal	Check sensor wire to see whether it is well connected or whether it is broken.
5	E02 on the screen	Error of PCB	Open circuit of IGBT-CE, replace PCB.

6	E03 on the screen	Big speed fluctuation	If this problem happened when speed is higher than 8km/h, the machine is overload, running belt is broken or lack of lubricant.
			If the motor has been used for a long time, replace the motor or replace the PCB.
7	E04 on the screen	Error of the communication line	Check connections of the meter and under control and make sure they are all well connected. Otherwise, replace some lines.
8	E05 on the screen	Current overload protection	Check the motor. If it's OK, restart the machine.
9	E06 on the screen	Error of the motor	Check whether the motor are well connected, Otherwise, replace the motor or PCB
10	E07 on the screen	Error of communication	Check connections of the meter and under control and make sure they are all well connected.
11	E08 on the screen	Overload protection	Make sure the weight of the user is not overweight. If so, add lubricant to the running board.
12	E09 on the screen	Overheat protection	Stop the machine and let it cool down. If this error happens when in normal temperature, then replace PCB.
13	E10 on the screen	Overvoltage protection	Check input voltage.
14	E11 on the screen	Undervoltage protection	Check input voltage.
15	E12 on the screen	Error of incline	Check whether the VR wire of incline motor is well connected. Then check other connections of incline motor are good. If there are lines broken, replace them.

Note: If the machine still doesn't work after taking these solutions, please contact our services as soon as possible.